

ENGINEERING DRAWING

(NSQF)

2nd YEAR
(For 2 Year Trades)

(As per Revised Syllabus July 2022)

Group 27

Marine Fitter



Directorate General of Training

DIRECTORATE GENERAL OF TRAINING
MINISTRY OF SKILL DEVELOPMENT & ENTREPRENEURSHIP
GOVERNMENT OF INDIA



**NATIONAL INSTRUCTIONAL
MEDIA INSTITUTE, CHENNAI**

Post Box No. 3142, CTI Campus, Guindy, Chennai - 600 032

Engineering Drawing (NSQF) 2nd Year (For 2 Year Trades)

Group 27 Engineering Trades

As per Revised syllabus July 2022 under CTS

Developed & Published by



National Instructional Media Institute

Post Box No.3142

Guindy, Chennai - 600032

INDIA

Email: chennai-nimi@nic.in

Website: www.nimi.gov.in

Copyright © 2023 National Instructional Media Institute, Chennai

First Edition : December 2023

Copies : 1000

Rs. 75/-

All rights reserved.

No part of this publication can be reproduced or transmitted in any form or by any means, electronic or mechanical, including photocopy, recording or any information storage and retrieval system, without permission in writing from the National Instructional Media Institute, Chennai.

FOREWORD

The Government of India has set an ambitious target of imparting skills one out of every four Indians, to help them secure jobs as part of the National Skills Development Policy. Industrial Training Institutes (ITIs) play a vital role in this process especially in terms of providing skilled manpower. Keeping this in mind, and for providing the current industry relevant skill training to Trainees, ITI syllabus has been recently updated with the help of comprising various stakeholder's viz. Industries, Entrepreneurs, Academicians and representatives from ITIs.

The National Instructional Media Institute (NIMI), Chennai, has now come up with instructional material to suit the revised curriculum for **Engineering Drawing 2nd Year (For 2 Year Trades) NSQF Group 27 Engineering Trades (Revised 2022)** under CTS will help the trainees to get an international equivalency standard where their skill proficiency and competency will be duly recognized across the globe and this will also increase the scope of recognition of prior learning. NSQF trainees will also get the opportunities to promote life long learning and skill development. I have no doubt that with NSQF the trainers and trainees of ITIs, and all stakeholders will derive maximum benefits from these IMPs and that NIMI's effort will go a long way in improving the quality of Vocational training in the country.

The Director General of Training, Executive Director & Staff of NIMI and members of Media Development Committee deserve appreciation for their contribution in bringing out this publication.

Jai Hind

ATUL KUMAR TIWARI, I.A.S.

Secretary
Ministry of Skill Development & Entrepreneurship,
Government of India.

December 2023

New Delhi - 110 001

PREFACE

The National Instructional Media Institute(NIMI) was set up at Chennai, by the Directorate General of Training, Ministry of skill Development and Entrepreneurship, Government of India, with the technical assistance from the Govt of the Federal Republic of Germany with the prime objective of developing and disseminating instructional Material for various trades as per prescribed syllabus and Craftsman Training Programme(CTS) under NSQF levels.

The Instructional materials are developed and produced in the form of Instructional Media Packages (IMPs), consisting of Trade Theory, Trade Practical, Test and Assignment Book, Instructor Guide and Wall charts. The above material will enable to achieve overall improvement in the standard of training in ITIs.

A national multi-skill programme called SKILL INDIA, was launched by the Government of India, through a Gazette Notification from the Ministry of Finance (Dept of Economic Affairs), Govt of India, dated 27th December 2013, with a view to create opportunities, space and scope for the development of talents of Indian Youth, and to develop those sectors under Skill Development.

The emphasis is to skill the Youth in such a manner to enable them to get employment and also improve Entrepreneurship by providing training, support and guidance for all occupation that were of traditional types. The training programme would be in the lines of International level, so that youths of our Country can get employed within the Country or Overseas employment. The **National Skill Qualification Framework (NSQF)**, anchored at the National Skill Development Agency(NSDA), is a Nationally Integrated Education and competency-based framework, to organize all qualifications according to a series of **levels of Knowledge, Skill and Aptitude**. Under NSQF the learner can acquire the Certification for Competency needed at any level through formal, non-formal or informal learning.

The **Engineering Drawing** 2nd Year (For 2 Year Trades) NSQF Group 27 - Engineering Trades (Revised 2022) under CTS is one of the book developed by the core group members as per the NSQF syllabus.

The **Engineering Drawing** 2nd Year (For 2 Year Trades) NSQF Group 27 - Engineering Trades under (Revised 2022) CTS as per NSQF is the outcome of the collective efforts of experts from Field Institutes of DGT, Champion ITI's for each of the Sectors, and also Media Development Committee (**MDC**) members and Staff of **NIMI**. NIMI wishes that the above material will fulfill to satisfy the long needs of the trainees and instructors and shall help the trainees for their Employability in Vocational Training.

NIMI would like to take this opportunity to convey sincere thanks to all the Members and Media Development Committee (MDC) members.

Chennai - 600 032

EXECUTIVE DIRECTOR

ACKNOWLEDGEMENT

The National Instructional Media Institute (NIMI) sincerely acknowledge with thanks the co-operation and contribution of the following Media Developers to bring this IMP for the course **Engineering Drawing 2nd Year (For 2 Year Trades) Group 27 - Engineering Trades** as per NSQF Revised 2022.

MEDIA DEVELOPMENT COMMITTEE MEMBERS

Shri. M. Sangara pandian	-	Training Officer (Retd.) CTI, Govt. of India, Guindy, Chennai - 32.
Shri. G. Sathiamoorthy	-	Jr.Training Officer - SG (Retd.) Govt I.T.I, Trichy, DET - Tamilnadu.
Smt. M.V. Vijayavalli	-	Assistant Training Officer, Govt. I.T.I., Ambattur, DET - Tamilnadu.

NIMI CO-ORDINATORS

Shri. Nirmalya Nath	-	Deputy General Manager, NIMI, Chennai - 32.
Shri. G. Michael Johny	-	Manager, NIMI, Chennai - 32.

NIMI records its appreciation of the **Data Entry, CAD, DTP Operators** for their excellent and devoted services in the process of development of this IMP.

NIMI also acknowledges with thanks, the efforts rendered by all other staff who have contributed for the development of this book.

INTRODUCTION

Theory and procedure along with the related exercises for further practice

This book on theory and procedure along with related exercises contains theoretical information on **2nd Year Engineering drawing** NSQF (For 2 Year Revised syllabus July 2022 Group 27 - Engineering Trades) and procedure of drawing/ sketching different exercise for further practice are also available. Wherever required, BIS specification has been used.

Exercise for further practice

The practice exercise is given with Theory and procedure for 2nd Year book made obsolete as it was felt that, it is very difficult to work in workbook using drawing instruments. It is well known fact that, any drawing is prepared on suitable standard size of drawing sheets only.

The instructor is herewith advised to go through the instructions given below and to follow them in view of imparting much drawing skill in the trainees.

Acquiring the above said ability and doing small drawings is not a simple task. These books will provide a good platform for achieving the said skills.

Time allotment - 2nd Year : 40 Hrs

Sl. No.	Topic	Exercise No.	Time in Hrs
1	Reading of drawing of nuts, bolt, screw thread, different types of locking devices e.g., Double nut, Castle nut, Pin, etc.	2.1.01	10
2	Reading of Rivets and rivetted joints, welded joints	2.2.02 & 2.2.03	10
3	Reading of drawing of pipes and pipe joints	2.3.04	10
4	Reading of Job Drawing & Assembly view	2.4.05	10
			40 Hrs

Instructions to the Instructors

It is suggested to get the drawing prepared on A4/A3 sheets preferably on only one side. If separate table and chair facility is available for every trainee then it is preferred to use A3 sheets and if the drawing hall is provided with desks then A4 sheets may be used. However while preparing bigger drawings on A4 sheets suitable reduction scale to be used or multiple sheets may be used for detailed and assembly drawings.

First the border and the title block to be drawn only for the first sheet of the chapter. Eg. for conical sections only first sheet will have the title block whereas the rest of the sheets of that chapter will have only borders.

Serial number of sheet and total no. of sheets to be mentioned on each sheet.

The completed sheet to be punched and filled in a box file/ suitable files and preserved by the trainees carefully after the approval of instructor, VP and Principal of the Institute.

The file may be referred by the authority before granting the internal marks at the end of the Year.

CONTENTS

Exercise No.	Topic of the Exercise	Page No.
2.1.01	Reading of drawing of nuts, bolt, screw thread, different types of locking devices e.g., Double nut, Castle nut, Pin, etc. Reading of drawing of nuts, bolt, screw thread, different types of locking devices e.g., double nut, castle nut, pin, etc.	1
2.2.02	Reading of Rivets and rivetted joints, welded joints Reading of rivets and rivetted joints	10
2.2.03	Welded joints	19
2.3.04	Reading of drawing of pipes and pipe joints Reading of drawing of pipes and pipe joints	21
2.4.05	Reading of Job Drawing & Assembly view Reading of job drawing & assembly view	26

LEARNING / ASSESSABLE OUTCOME

On completion of this book you shall be able to

- **Read and apply engineering drawing for different application in the field of work. NOSCSC/N9401**

SYLLABUS

2nd Year

**Group 27 - Revised syllabus July 2022
2 Year Engineering trades under CTS**

Duration: 2 Year

CTS Trades Covered: Marine Fitter

S.no.	Syllabus	Time in Hrs
1	Reading of drawing of nuts, bolt, screw thread, different types of locking devices e.g., Double nut, Castle nut, Pin, etc.	10
2	Reading of Rivets and rivetted joints, welded joints	10
3	Reading of drawing of pipes and pipe joints	10
4	Reading of Job Drawing & Assembly view	10
	Total	40

Reading of drawing of nuts, bolt, screw thread, different types of locking devices e.g., double nut, castle nut, pin, etc

Screw Thread

External thread: It is the thread formed on the outside of a shaft e.g., bolt, screw and stud.

Internal thread: It is the thread formed inside a component say a hole or Nut.

Elements of screw thread: Fig 1 shows elements of a 'V' thread.

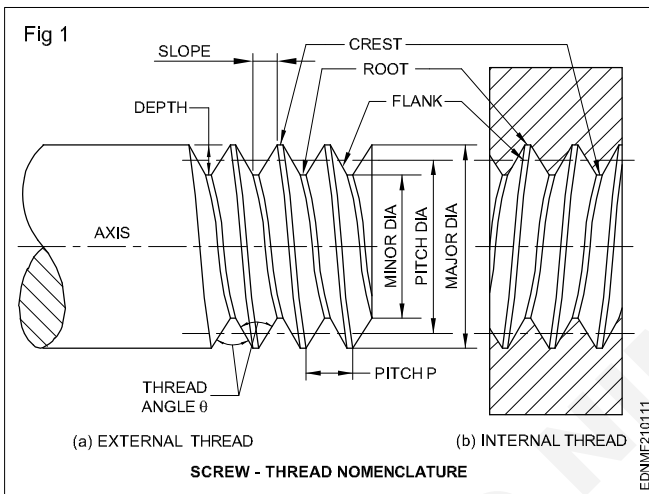

Right hand thread: is a thread that advances into the work when turned clockwise. It is the commonly used thread unless and otherwise stated. (Fig 2a)

Left-hand thread: It is the thread that advances into engagement when turned anti clockwise. (Fig 2b)

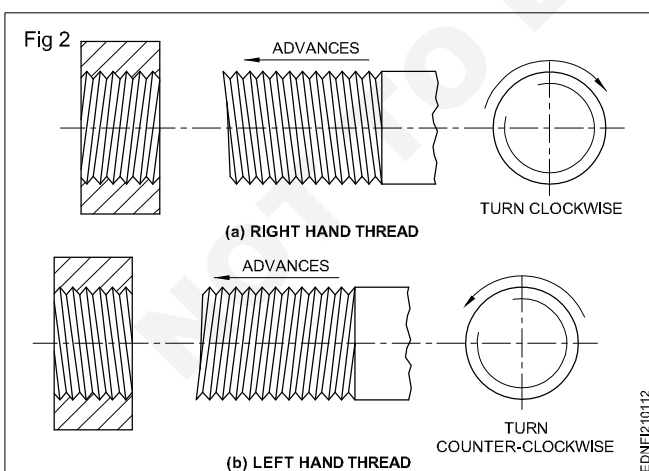

Single start thread: it is a thread form, cut on the cylinder. Unless otherwise stated, threads are single start thread, also called single start. (Fig 3a)

Multiple or multistart threads: a thread combination of same profile formed by two or more helices on the cylinder. For single revolution, the axial movement of nut or screw is double, triple or quadruple depending on the start of the thread. (Figs 3b, c, d & e)

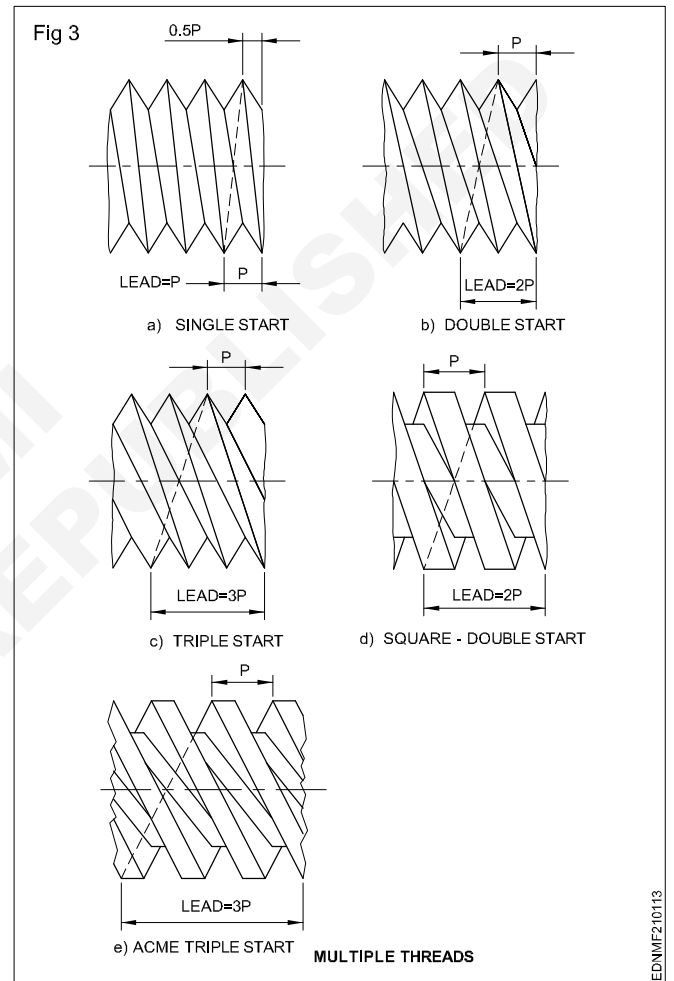

Vee threads

Types of 'V' threads: Fig 4 shows the proportions of the thread profile of BSW. Its thread angle is 55°.

British Standard Fine (BSF) threads: Profile of the BSF thread is same as of BSW (55°). BSF threads are used in Automobile, Air crafts and for fine mechanisms. Since the pitch is small.

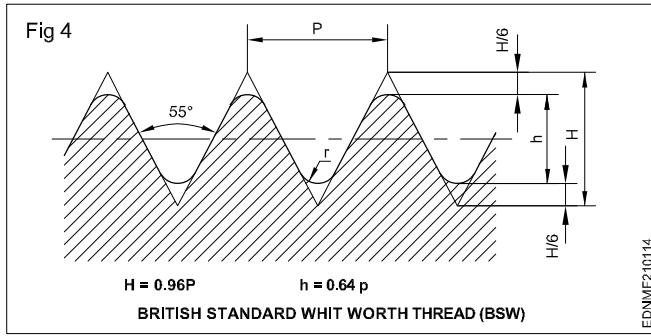

British Association thread (BA thread): Its angle is $47 \frac{1}{2}^\circ$. (Fig 5)

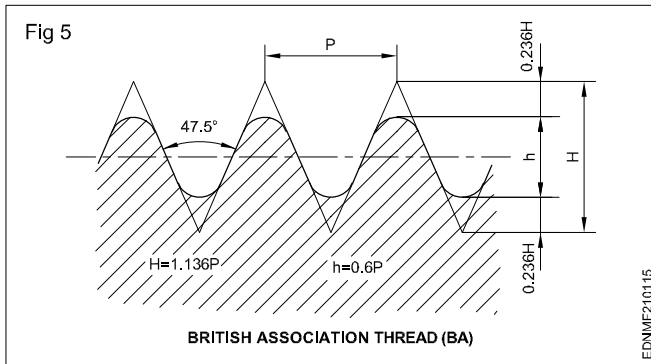

Metric threads: IS:4218 Bureau of Indian Standards (BIS) has recommended the use of ISO metric threads. Its thread angle is 60° . Fig 6a & b shows the metric thread form with proportions.

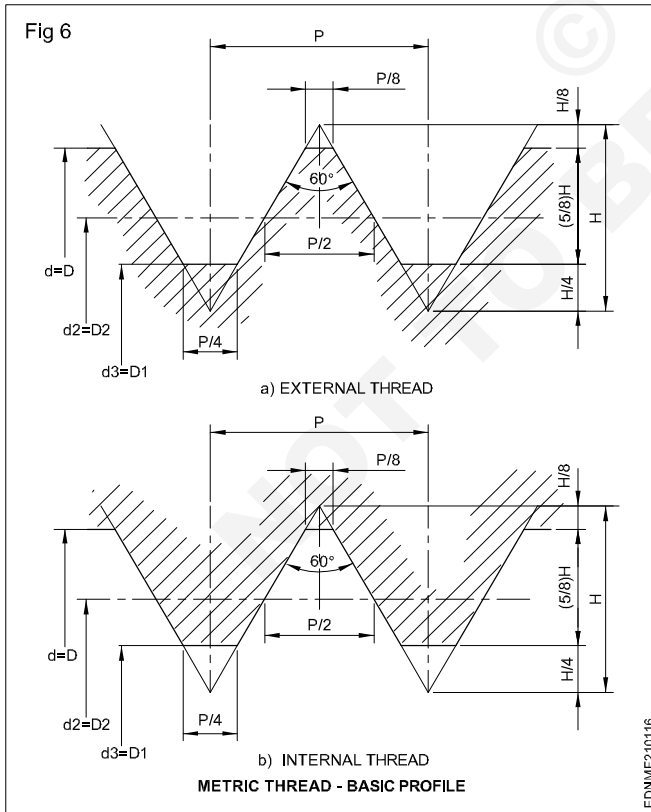

Types of Threads

1 Square thread (Fig 7)

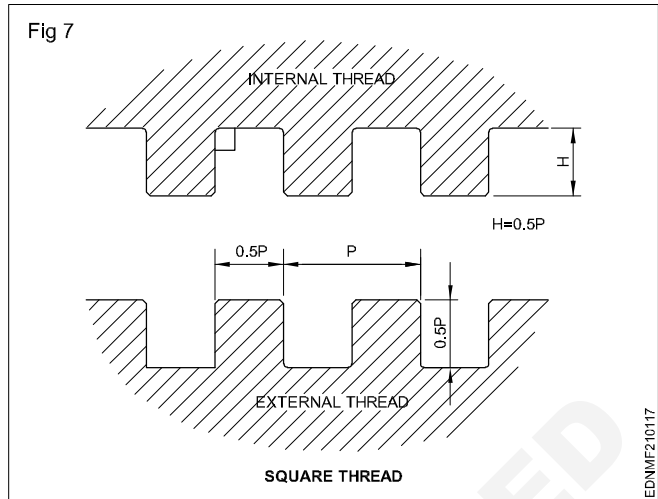

2 ACME thread (Fig 8)

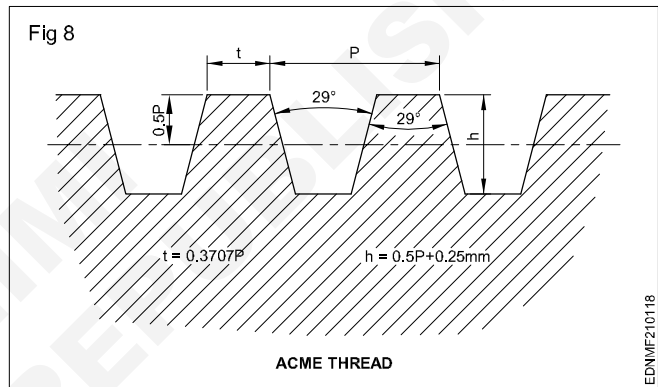

3 Only 45° Buttress thread (Fig 9)

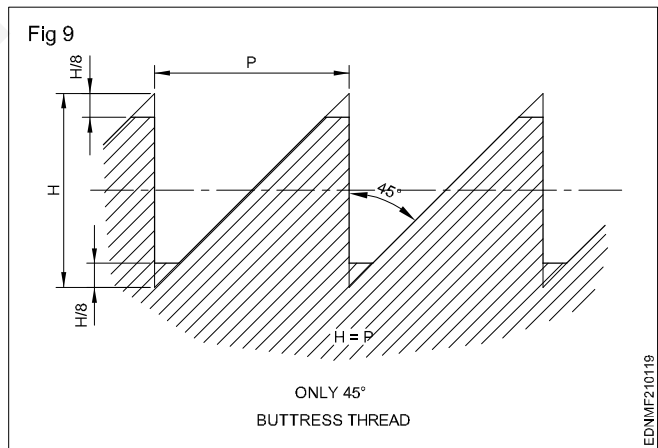

4 Convention of internal thread (Fig 10)

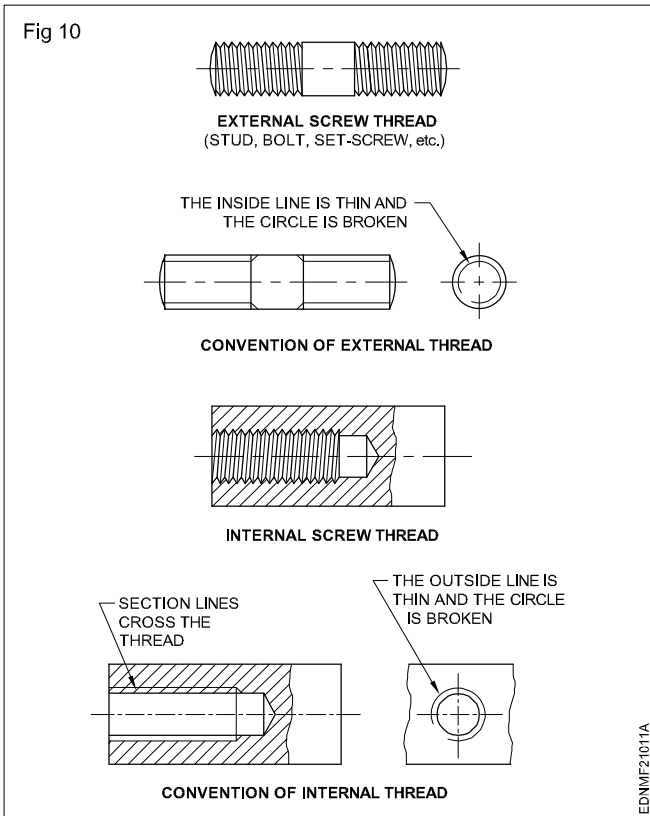

5 Knuckle thread (Fig 11)

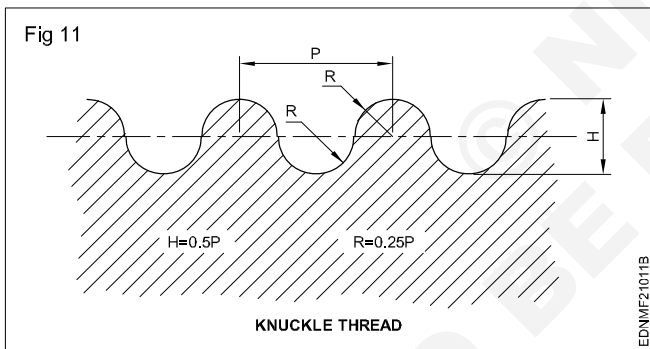

Bolt

Type of Bolt

Hexagonal head bolts (Fig 1&2)

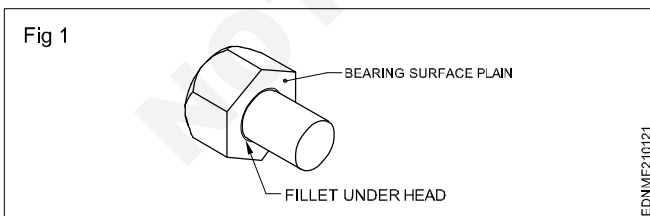

There are three grades of hex. head bolts viz (i) Precision, (ii) Semi precision and (iii) Black denoted by letters A, B & C respectively according to their dimensional accuracies.

Hexagonal bolts Grades A and B IS: 1364 part-1 M3 to M36. (12 Sizes)

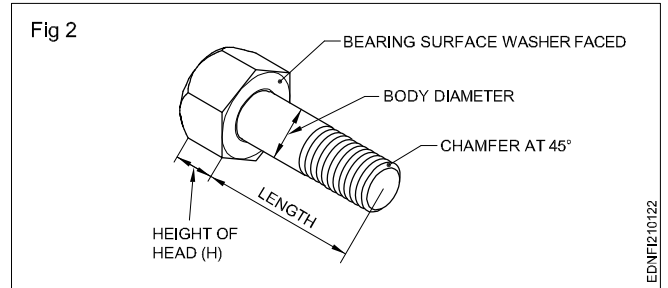

Grade C IS: 1363-part-1 M5 to M36 (10 sizes)

Grade C Black IS: 3138 M42 to M156 (23 Size) are available.

Square head bolt: Fig 3 shows a square head bolt of plain shank and with square neck. They are of grade C (black) IS: 2585 Diameters available from 6 to 39 mm (15 sizes).

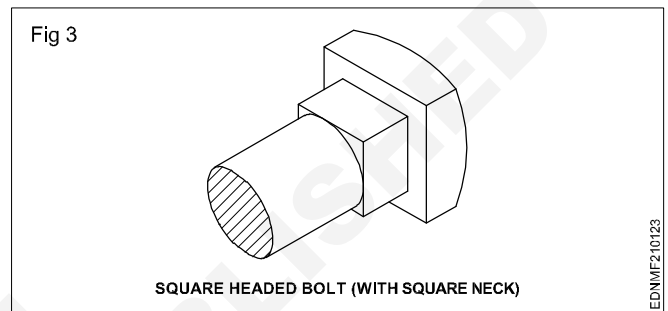

Cylindrical or Cheese head bolts (Fig 4): There is no need to use spanner to hold the head. It is most commonly used on big ends of connecting rods, eccentrics etc.

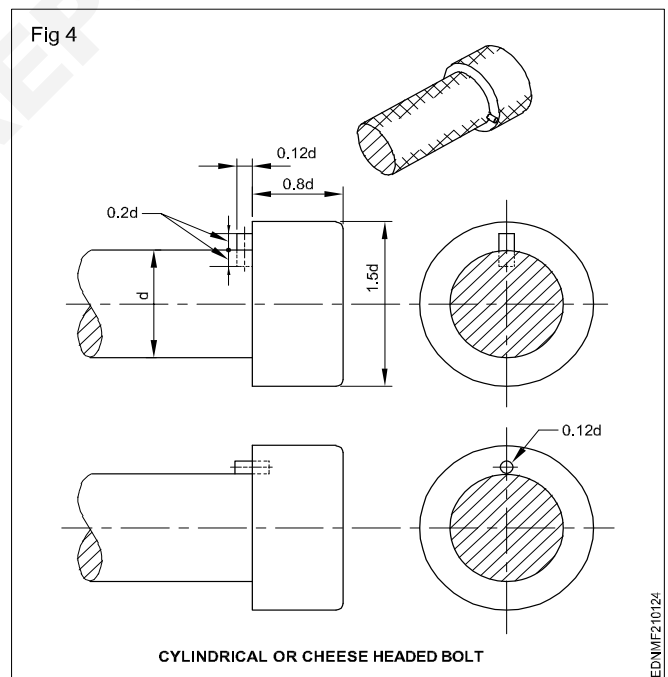

Cup head or round head bolt: It has hemispherical head with a snug or square neck. The snug is formed while forging. Its function is same as round head bolt. (Fig 5)

Standard 'T' bolts: There are T bolts as per IS: 2014 to suit T slots according to IS: 2013. (Fig 6)

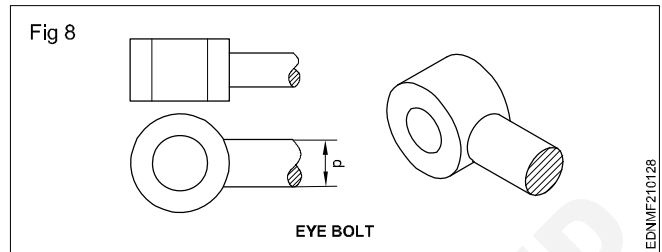
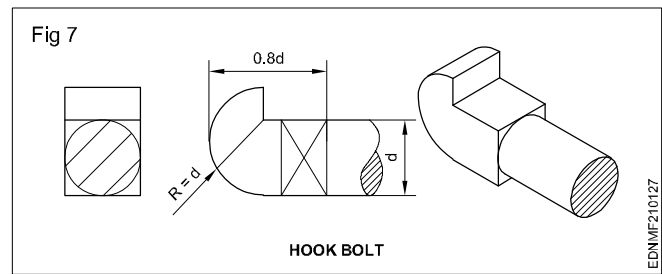
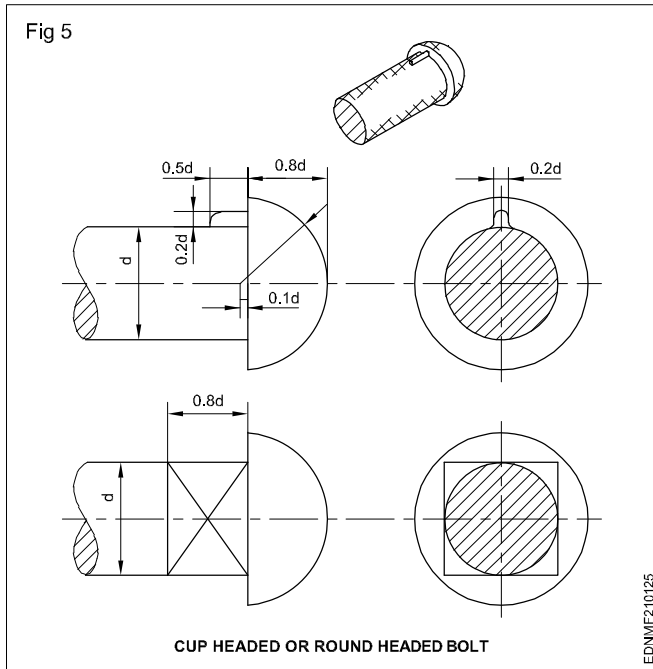

Lifting eye bolt (Fig 9): The shank is threaded and fits into the machine/motor body. It is used to lift the machines or motors for shifting and aligning during erection.

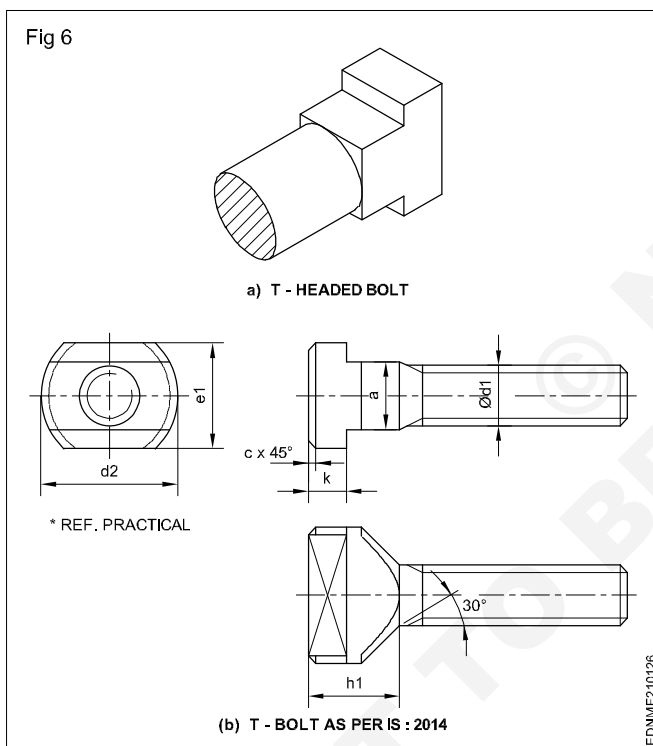

Hook bolt: It is slightly different from 'T' head bolt. It is used when it is not possible to drill a hole in the component in position. (Fig 7)

Eye bolt: It has a short hollow cylinder head attached to the shank perpendicular to its axis. Because of its flat circular faces, rotation of bolt is prevented while handling nut. (Fig 8)

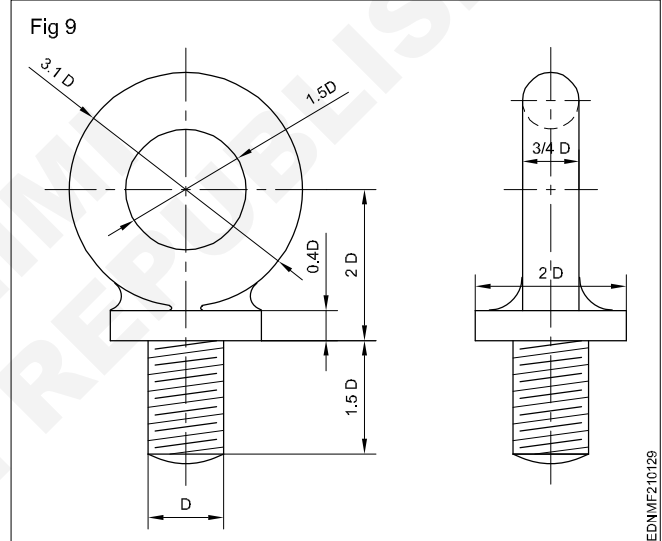

Counter sunk head bolt (Fig 10): It has a counter sunk head which does not project outside the hole.

Cap screw or tap bolt: It is used to where there is no possibility of using a nut, assembly and a clearance hole is drilled on the part to be fitted. (Fig 11)

Hexagonal socket head cap screw (IS:2269): These are available from M1.6 to M36 (16 sizes), length 2.3 mm to 200mm depending upon the dia.

They are used on machine tables and on assemblies. (Fig 12) It is operated with an allen key.

Designation: A hexagonal socket cap screw of size M12 length 60 mm property class 12.9 shall be designated as Hexagonal socket head cap screw M12 x 60-12.9-IS:2269.

Fig 10

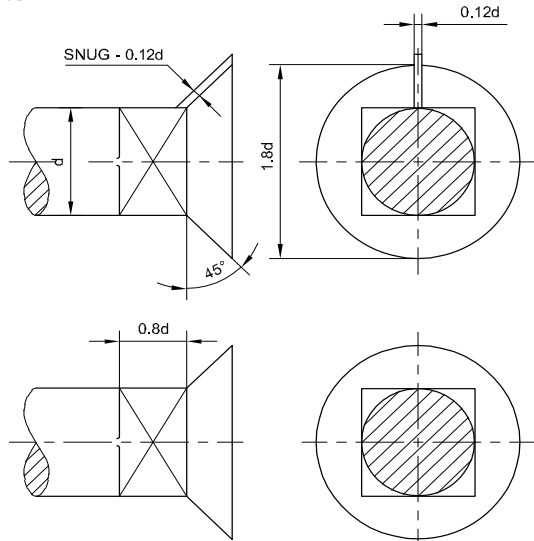

COUNTER SUNK - HEAD BOLT

EDNMF21012A

Nuts and washers

Nut is a metallic piece of definite shape with threaded (screwed) hole on the centre of the face. It is used on the end of the bolt/screw to hold the parts in position.

Nuts are known by their shape or their cross-section. The most commonly used forms are hexagonal and square. Nuts are specified by the shape of the nut and the nominal dia of bolt/screw on which they are used. (Fig 1)

Fig 1

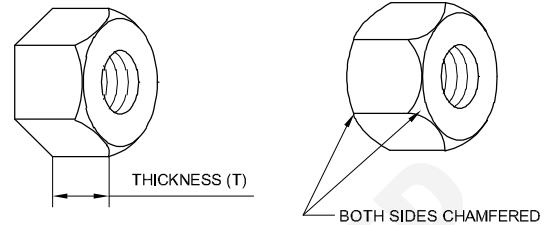

EDNMF210131

Hexagonal nut (Fig 2): it is made of hexagonal bar with a screwed/threaded hole in the centre. To avoid the damaging of the corners on the face, they are chamfered at 30°, with reference to the base. Theoretically the thickness of the nut is equal to the diameter of the bolt and corner to corner is 2d i.e., twice the diameter of the bolt (approximately).

The actual sizes are specified in IS:1363, 1364, 3138.

Thin hex.nuts are available IS:1364 (Part-4).

Fig 11

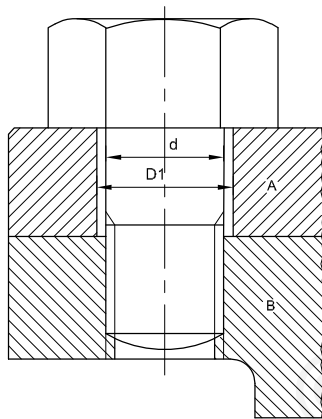

TAP - BOLT OR CAP - SCREW

EDNMF21012B

Fig 12

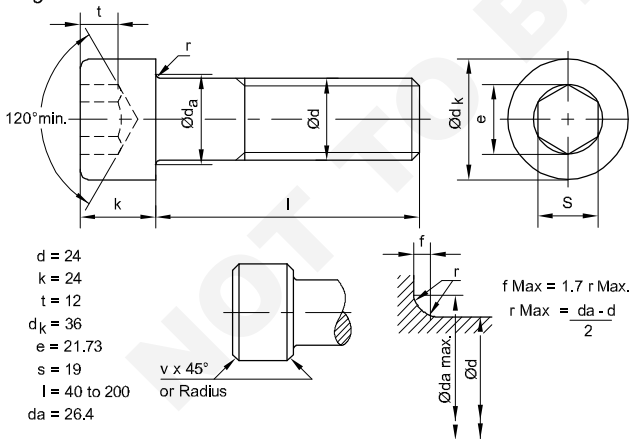

EDNMF21012C

Fig 2

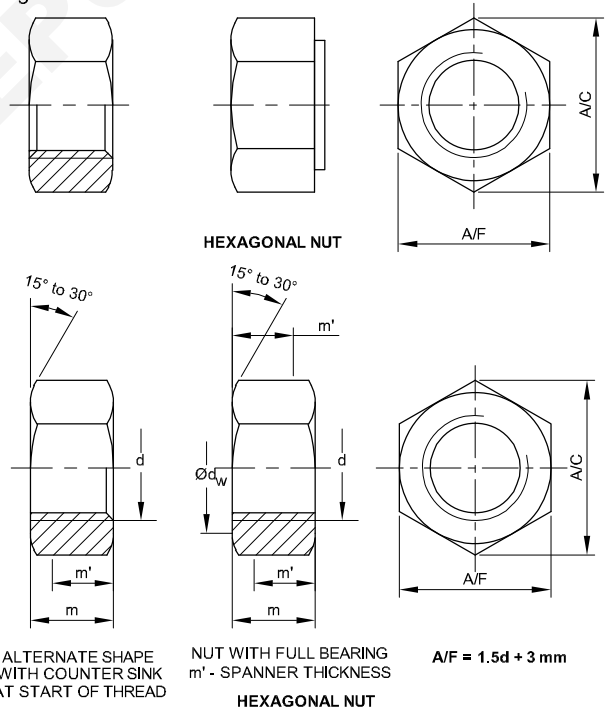

EDNMF210132

Square nut (Fig 3): It is made out of square bar. Side of the square is equal to $1.5d + 3 \text{ mm}$ and radius of the chamfer is $2d$. Sizes are from M6 to M39.

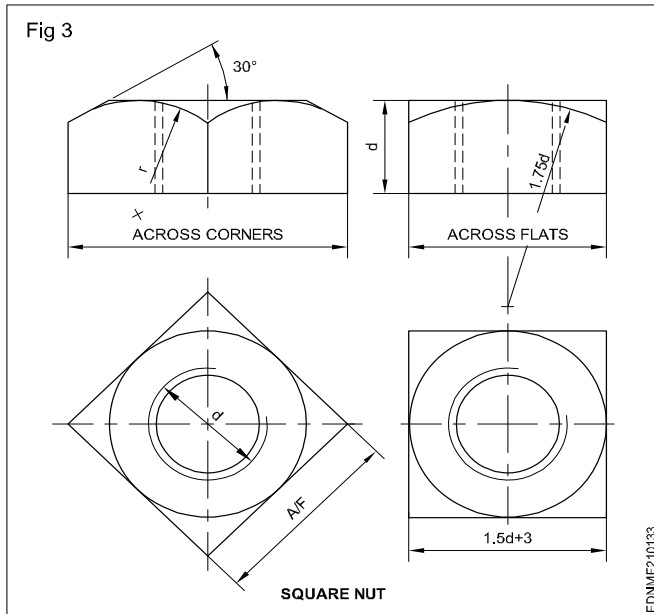

IS:2585 lays down the standard sizes available.

For drawing purposes, the following sizes of the nut are considered.

Bolt nom. dia = d

Thickness of nut $T = d$

Width across Flats (A/F) $W = 1.5d + 3\text{mm}$

Angle of chamfer = 30°

Radius of chamfer arc = $2d$ (approx.)

Special Nuts

Collared nut: It is a regular hexagon nut with a washer face. It avoids cutting groove on the metal while tightening and also can be used on comparatively larger holes. It is available from M8 to M36 IS:7795-1975. (Fig 4)

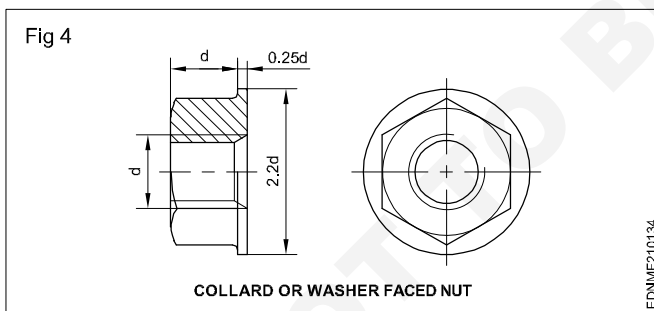

Cap nut: it is also a hexagonal nut, the hole covered by a cylindrical flat cap. It protects the end of the bolt from corrosion and leakages of oils through the threads. Figure shows the nut. It has a cavity of $0.25d$ and end metal thickness $0.25d$. (Fig 5a)

Domenut(as per BIS) Domenut: it is a hexagonal nut with blind hole having hemispherical top end. Its use is same as above. Dome nut is available from M6 to M34 IS:2687

It is made of steel, brass or aluminum. Steel nuts may be from rolled, forged or extruded. Nuts of sizes M24 and above. (Fig 5b)

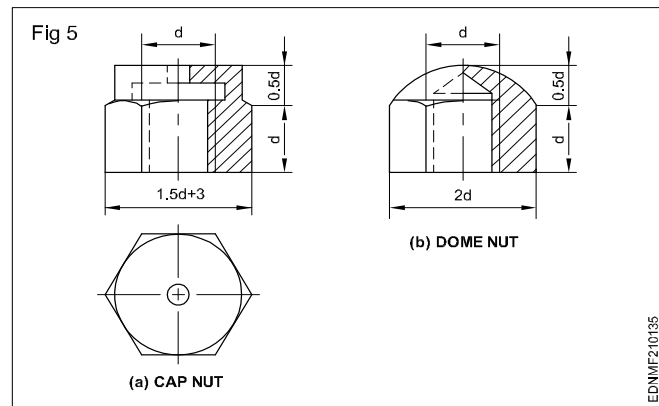

Capstan nut or cylindrical nut: It has six blind hole equispaced on the circumference. The diameter and depth of the hole is equal to $0.2d$. Diameter of the nut is $1.8d$. A hook spanner is used to operate. (Fig 6)

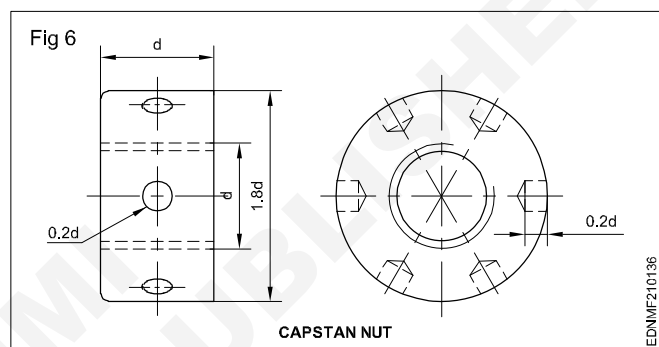

Ring nut: Its diameter is $1.8d$ and thickness is $0.5d$. The thickness is reduced to $0.3d$, by $0.1d$ from both the faces forming $1.5d$ cylindrical faces. Six slots of $0.2d$ width are milled on the circumference to the depth of $0.15d$. Special spanner is used to operate the nut. (Fig 7) These are used in pairs, one nut acting as a lock nut.

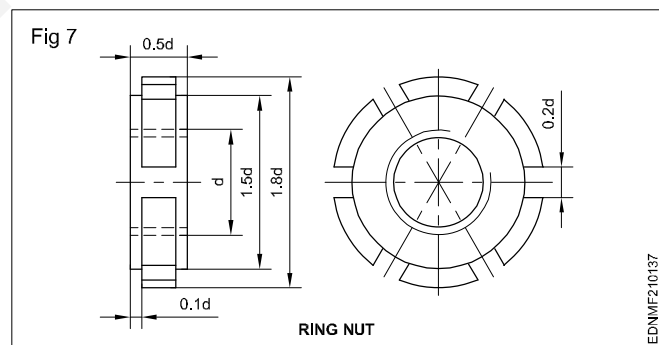

Domed Cap nut (IS:7790): Hexagon nut with a hemispherical top. Its function is similar to cap nut. It is available in 11 sizes from M6 to M24 diameter bolts/screw. They are made of steel, brass or aluminum alloy. It prevents corrosion and leakage of fluids from the threads. (Fig 8)

Washer: It is a cylindrical thin disc with a hole in the centre. Washer helps to provide smooth bearing surface between the nut and the part on which it is used. There by it prevents the nut corners from cutting into the metal. (Fig 9)

There are plain washers (IS:2016:5370) and spring washers (IS:6755,3063,6735).

Plain washers are available from basic hole size 4 to 155 mm dia to suit bolt/screw size from M 1.6 to M 150 mm. One face is chamfered at 45°. While spring washer exerts pressure on the nut tightening and keeps the thread gripped on the thread.

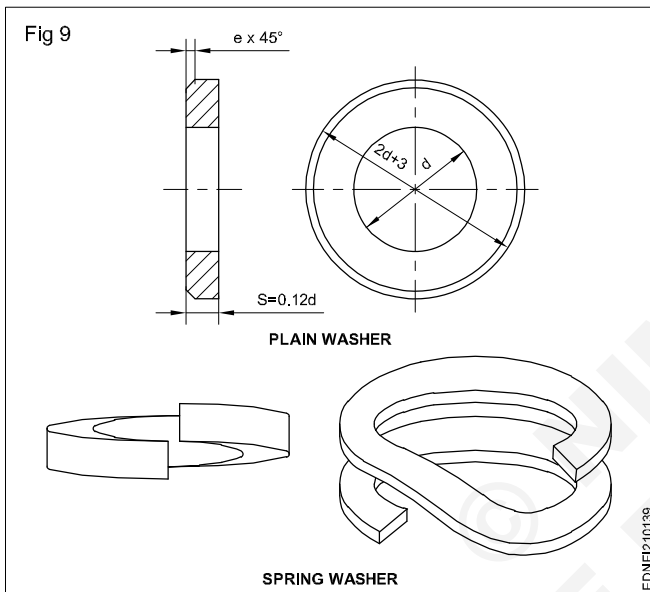
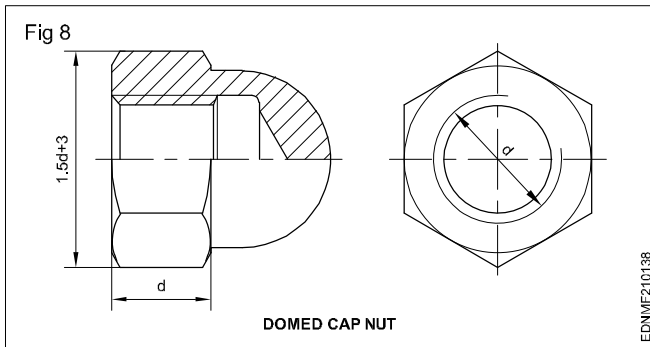

Screws

Grub screws are comparatively smaller in dia and short in length. They are made of hardened steel, used for holding two parts in position eg., a collar pulley, or gear on a shaft.

On driving it into position, it produces a clamping force, resists relative motion between the assembled parts. The grub screws are fully cylindrical, on one end they are provided with hexagonal socket or screw driver slot. On the other end they are formed into different points. (Fig 1)

Hexagonal socket grub screws or screw driver slot are of following types.IS: 6094 (Fig 1)

They are namely as follows:

- Flat point (FP)
- Cone point (TP)
- Full dog point (FDP)
- Half dog point (HDP)
- Cup point (CP)
- Conical point

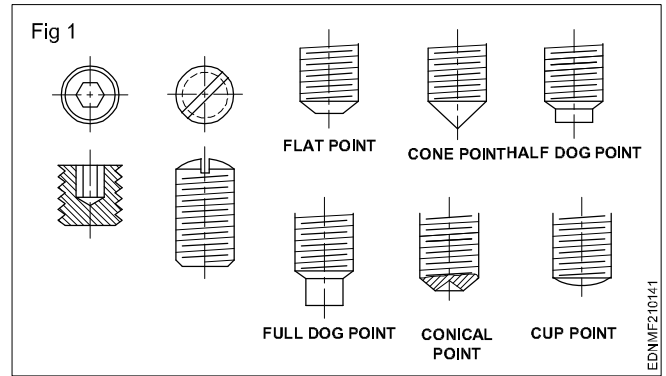

These are designated by the shape of their ends. These are available in sizes M3, M4, M5, M6, M8, M10, M12, M16, M20, M 24, Max. length 60 mm. These are operated by using hex. bent key (Allen key).

Slotted grub screws as per IS:2388 are designated by letters. (Fig 2)

- i) Type A - Flat end
- ii) Type C - Conical end
- iii) Type E - Cylindrical dog point
- iv) Type G - Tapered dog point
- v) Type J - Cup point
- vi) Type K - Oval point

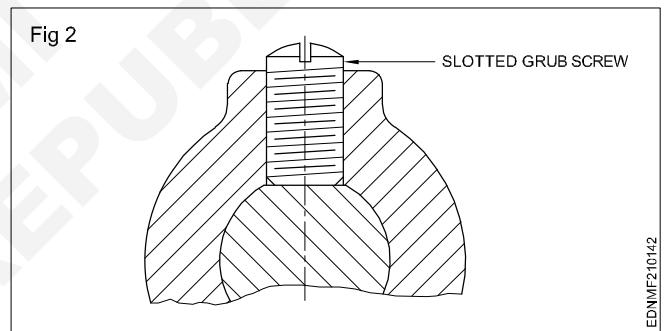

Set screws (Not as per BIS): These screws are operated by screw drivers or a spanner. They are available in different sizes M1 to M24. The lengths vary according to dia.

Screws are specified by designating the head, diameter; length and IS:No and property class.

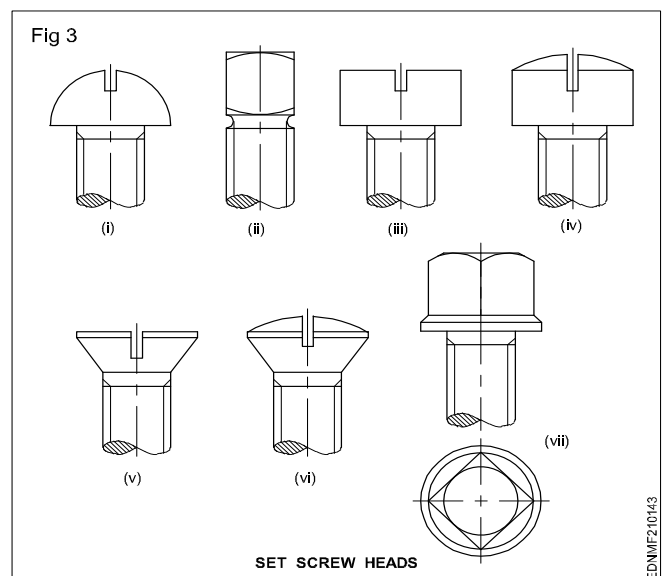

Locking devices

Locking devices: There are different types which are used to prevent nuts from getting loose on machines subjected to vibrations or impacts.

The most commonly used device is a lock nut. It is an additional nut called Lock nut engaged on the other. The thickness of lock nut may be $0.6d$ to $0.8d$; d being the diameter of the bolt. The top nut when tightly engaged on the nut, it prevents the nut becoming loose. (Fig 1)

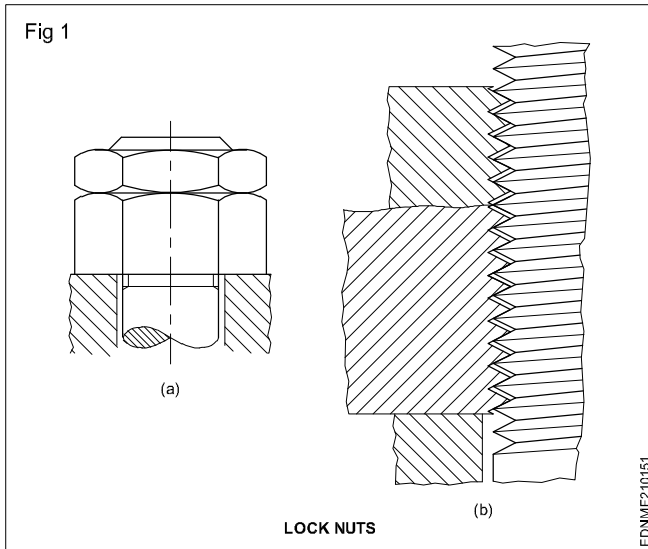

Split Pin: It is made of semi circular steel wires (IS:549) bent through 180° , forming a spherical head. It is passed through the split pin holes in the bolt/screw ends and the ends are opened back wards. There by it locks the nuts in their position. They are available in 16 sizes, 0.6 mm to 20 mm depending upon the bolt dia 2.5 to 170 mm dia. (Fig 2)

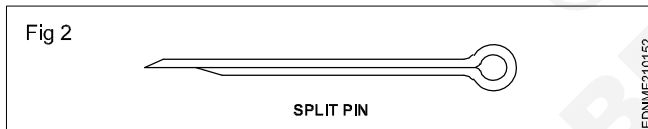

Slotted nut IS:2232: It is a hexagonal nut with slots of width $0.25d$ cut on the top end of the nut through the opposite faces. A split pin is inserted through the slot in the hole drilled on the bolt end in line with the slot. The split end of the pin is opened securing the nut. The width of the slot is $0.25d$ and $0.3d$ deep, split pin dia is $0.2d$. (Fig 3)

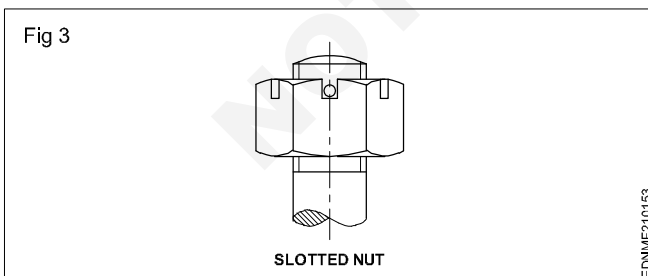

Castle nut IS: 2232: It is similar to slotted nut with semi circular end slots cut on the cylindrical part called "castle", on the nut. A split pin is passed through and lock the nut. (Fig 4)

The above are available in grades A,B & C sizes M4 to M100.

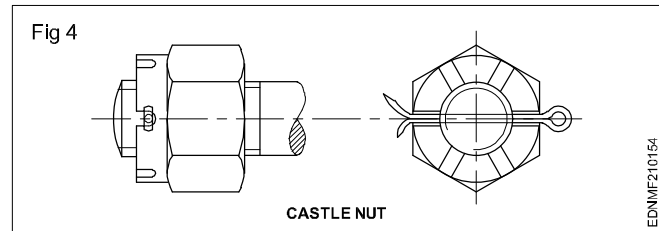

Sawn nut or Wiles nut: It is a normal hexagonal nut cut half way through one of its corners. The width of the slot is $0.15d$ located at $0.2d$ from top of the nut. A tapped hole is cut on the nut as shown. A set screw when tightened at the top thin part of nut slightly bends, there by pressing on the threads. This prevents the slackening of nut. (Fig 5)

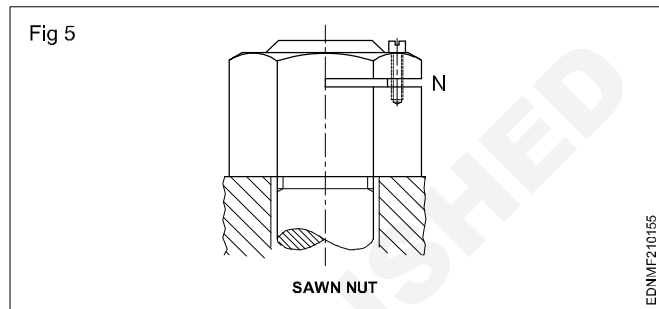

Simmond's lock nut: The hexagonal nut has a closed cavity on one end and a fiber ring is fitted inside it. The internal dia meter of a fiber ring is slightly less than the core diameter. When the nut is screwed down, bolt end cuts thread on the fiber ring.

The fiber ring gives greater grip over the bolt threads and prevents slackening the nut. (Fig 6)

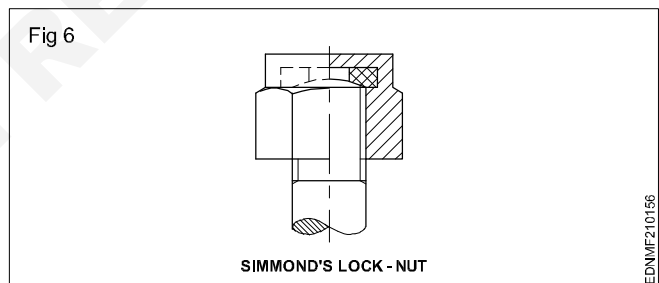

Penn, ring or grooved nut: A part of the nut is turned round with a round groove. When the bolt hole is very close to the edge, a counter bored hole is provided. The dog point of set screw, through the tapped hole, sits on to the groove. When screwed in, the nut is prevented from getting loosened. (Fig 7)

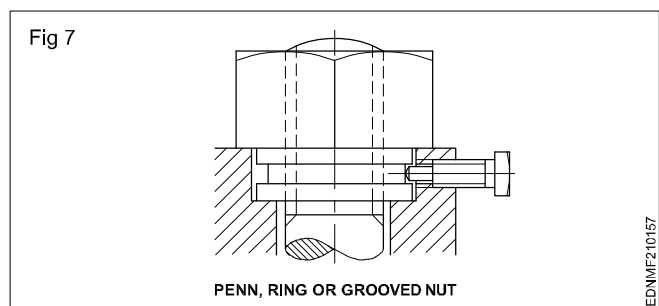

The same nut can be locked as shown in Fig 8 with a collar when it is away from edge.

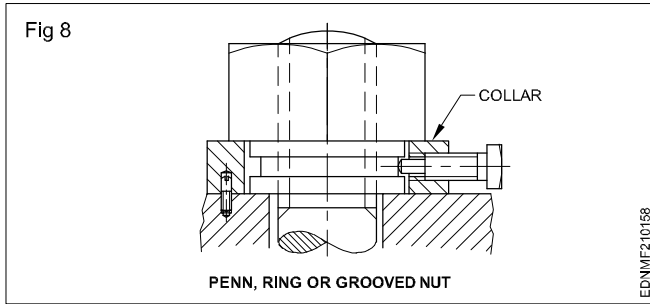

Locking by Locking plate or stop plate: a plate with grooves to suit the nut is placed on the nut and screwed down to the body with a screw. (Fig 9)

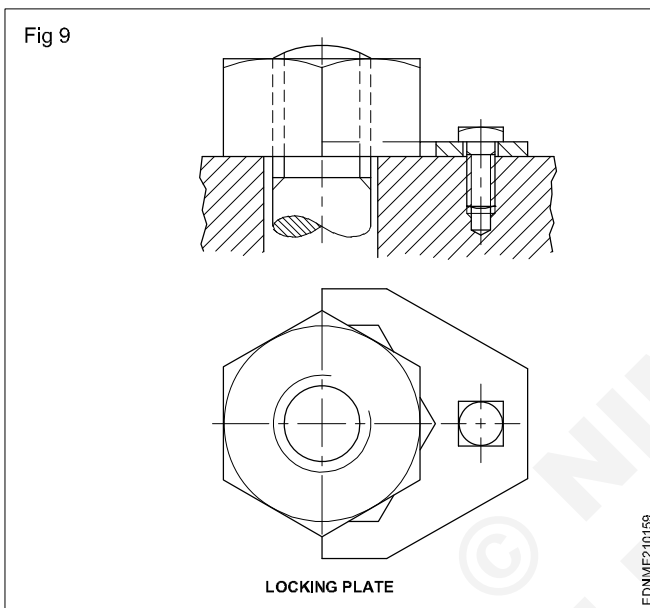

Locking by screw: A screw fixed by the side of the face prevents movement of the nut. (Fig 10)

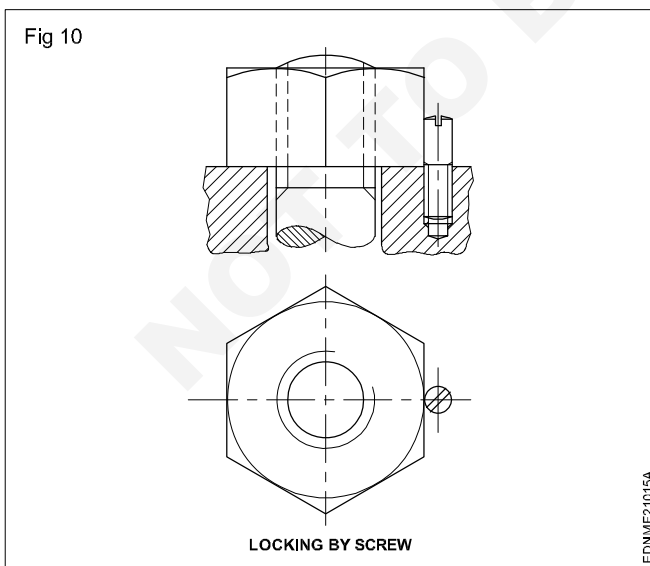

Apart from the methods mentioned above, spring washers, single coiled or double coiled washer are used to lock the nuts. By tightening the nut, the nut presses the spring and deform. This exerts pressure on the nut, prevents rotation of nut, when tightened in position. (Fig 11)

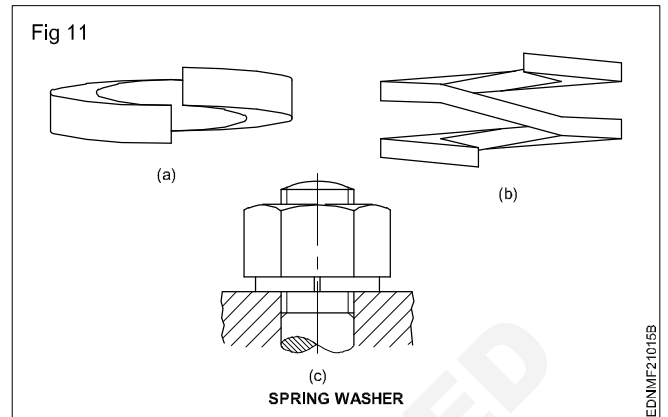

Locking by wire: screw ends have holes through which wire is passed after the nuts are screwed down. Wire prevents nuts coming off.

Stud or stud bolt (Fig 12): It is only a cylindrical shank having threads on both ends, with the plain portion in between. One end is shorter, that is screwed into the machine body called "Metal end". The other end longer one which takes nut is called Nut end. (Fig 12a) Some studs have a collar called "collar studs". (Fig 12c) Studs are screwed into the metal end, using double (lock nut) method. After removing the nuts, the other part with plain hole is placed in position and nuts are screwed on to the nut end. (Fig 12b)

There are three types of studs:

Type A - recommended for use in steel; metal end length = 1 d.

Type B - recommended for use in cast iron; metal end length = 1.5d.

Type C - recommended for use in aluminum, metal end length = 2 d

M4, M8, M12, M16 & M20 are available. Lengths 25 mm to 200 according to dia.

Designation stud B M24 x 200 IS:1862.

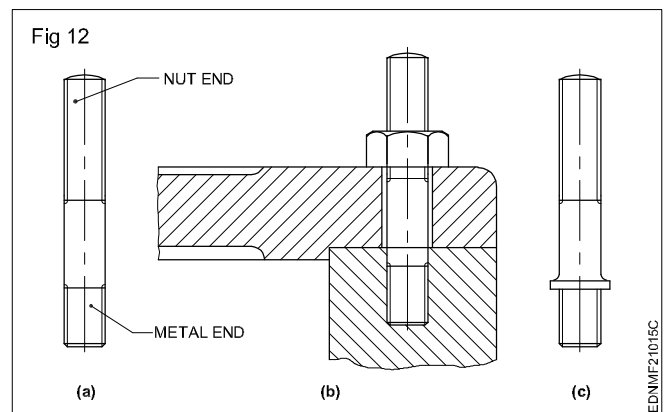

Reading of rivets and rivetted joints

Rivet is a cylindrical rod of either carbon steel or wrought iron or non-ferrous metal. It consists of a head and shank tapering at the end facilitating easy placement in the rivet holes. Rivets are used to hold the plates or steel sections firmly, just as in steam boilers, girders, steel structures, ship building. The rivet holes are made either by punching or by drilling. When the plates are aligned, the heated rivets are placed through the holes. By using rivet sets, the tail part of the shank is formed into the head closing the hole. The plates are held firmly between the heads on cooling. To prevent leakages of boiler shells, during which the plate ends and rivet head end are pressed by hammering using a tool similar to blunt cold chisel. Fig 1 shows how riveting is done.

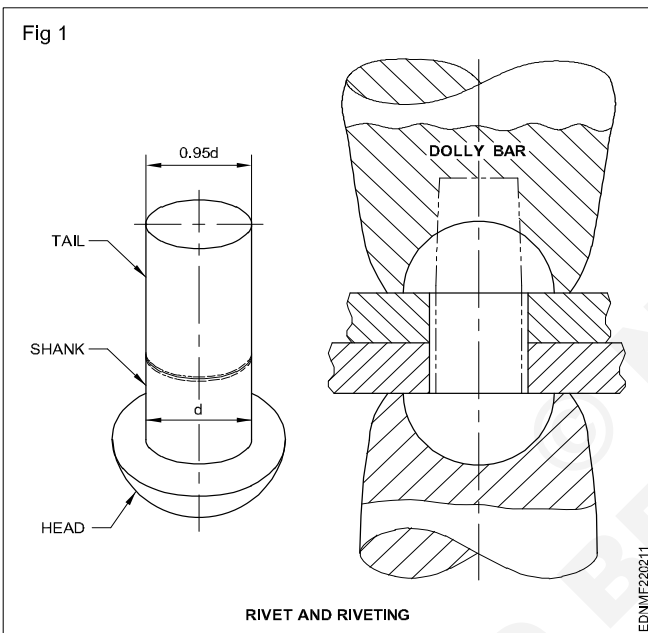

Types of rivets:

- Boiler rivets
- Hot forged rivets for hot closing
- Cold forged solid steel rivets for hot closing
- Non-ferrous rivets
- Cold forged rivets for cold closing
- Bi-furcated rivets for general purposes
- Solid drilled tubular and semi-tubular rivets.

Rivets are also broadly classified as:

- Structural rivets
- Boiler rivets
- Small rivets for general work
- Rivets for ship building
- Aircraft rivets.

They are available in different lengths and selected according to the requirements (IS:1928 for boiler rivets, dia 12 to 48mm).

Boiler rivets of different types of heads as per IS:1928-1961 are shown in Fig 2. They are

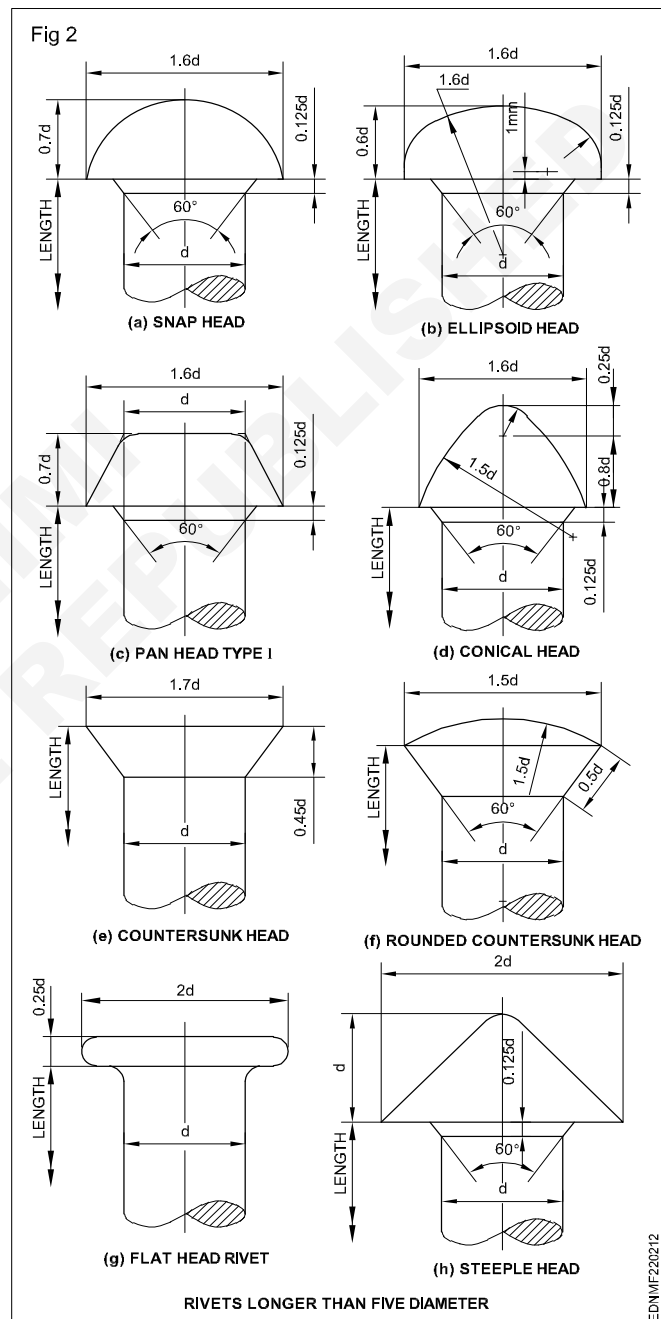

- Snap head
- Ellipsoidal head
- Pan head type I & II
- Pan head with taper neck
- Conical head
- Countersunk head
- Rounded countersunk head
- Flat head
- Steeple head

Hot closing rivets (Fig 3)

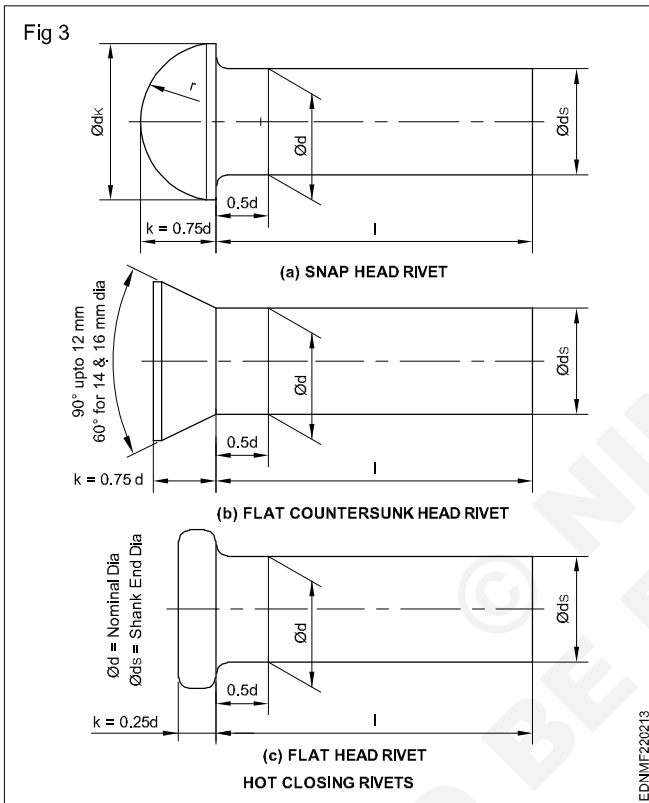

Ship building rivets (Fig 4): (IS:4732)

- Snap head
- Countersunk head.

The dia ranges from 16 to 33 mm in steps of 2 mm upto 24 mm and rest in steps of 3 mm. The length of rivets vary from 27 mm to 180 mm in steps of 3 mm. They are made of mild steel bars.

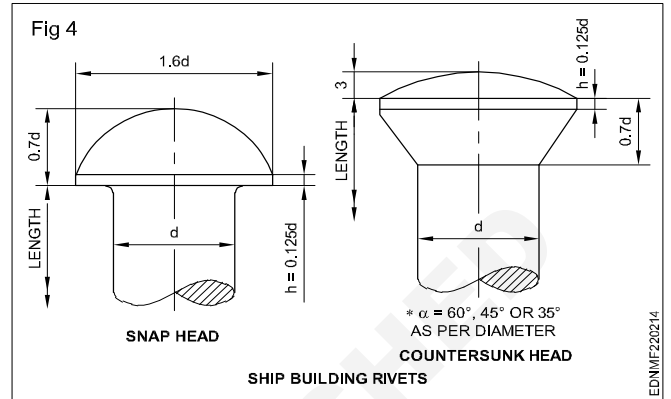

Selection of rivet dia: The diameter of the rivet is based on the thickness of the plates to be joined. A general formula to find the dia 'd' for plate thickness 't' is

$$d = 6\sqrt{t}$$

where 't' is in millimeters.

$$d = 1.2 \sqrt{t} \text{ to } 1.4 \sqrt{t}$$

where the 't' is in inches.

Recommended value

Thickness of plate t in mm

8, 9, 10, 11, 12, 14, 16, 18, 20, 22, 25

Dia of rivet d in mm

17, 18, 19, 20, 21, 22, 24, 25, 27, 28, 30

Length of rivet is selected according to the thickness of plates and just long enough to fill the hole completely and make the head. Rivet joints are formed by drilling holes in plates together (grade of hole H 12). The rivet is placed through the holes and the shank is either hot forged or cold forged.

Table 1

Rivets for general purposes and boiler rivets (12 to 48 mm diameter) IS:1929-1961 IS:1928-1961			
Snap head rivet for boilers	Snap head rivet for general purpose	Rounded countersunk head for general purpose and boilers	Flat countersunk head for general purpose and boilers
Basic size of rivets, D, mm: 12 14 16 18 20 22 24 27 30 33 36 39 42 48			

Practice of standard rivet forms as per BIS

1 Snap head rivet (Fig 1)

Draw a snap head rivet suitable for joining plates of 25 mm thick.

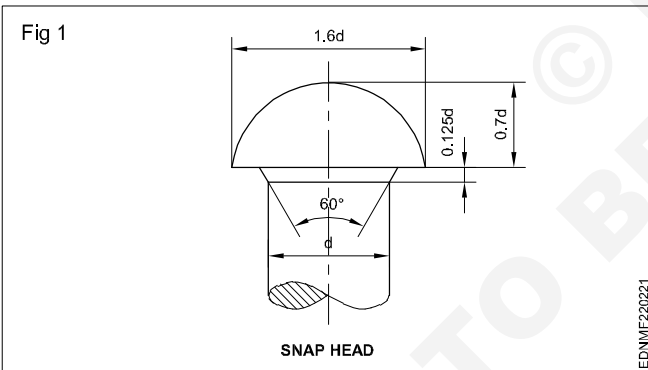

2 Pan head rivet

Draw a pan head rivet of shank diameter 30 mm. (Fig 2)

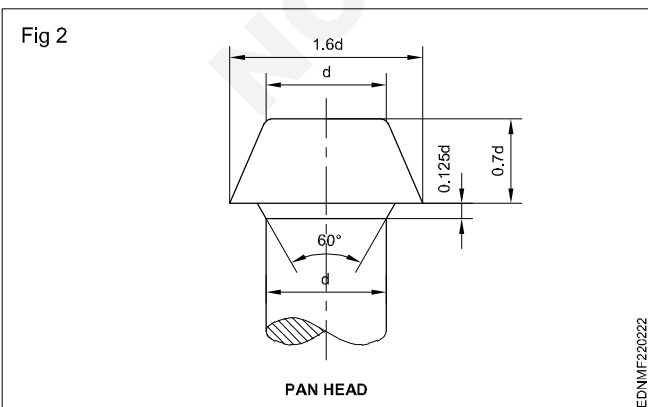

3 Conical head rivet

Draw a conical head rivet of shows diameter 25 mm. (Fig 3)

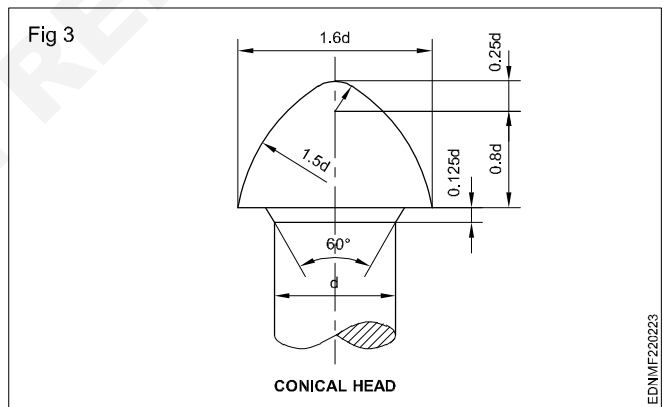

4 Countersunk head rivet

Draw a countersunk head rivet of shank diameter 25 mm. (Fig 4)

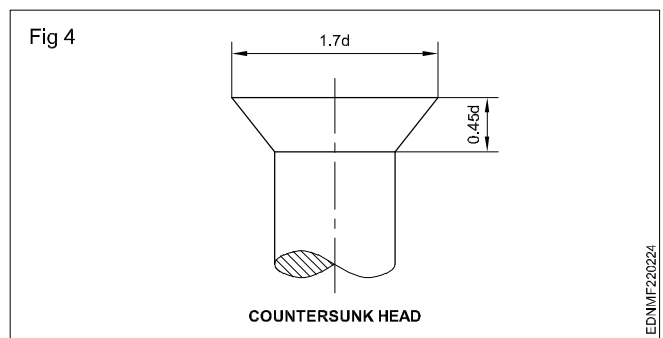

Riveted joints

Types of riveted joints

- Lap joint
- Butt joint

When the plates are placed one above the other, the joint is called Lap joint. The distance between the centres of adjoining rivets in the same row is called the pitch. (Fig 1)

In the lap joints only two plates are used placing one over the other and riveted. In butt joints, the plate ends are placed face to face, single or double cover plates are used to rivet them together.

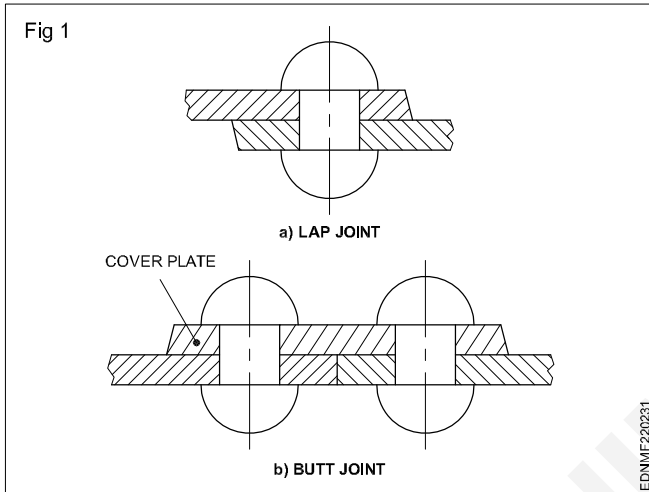

When the number of rows are two or more, rivets are arranged in chain or zig-zag formation. (Fig 2)

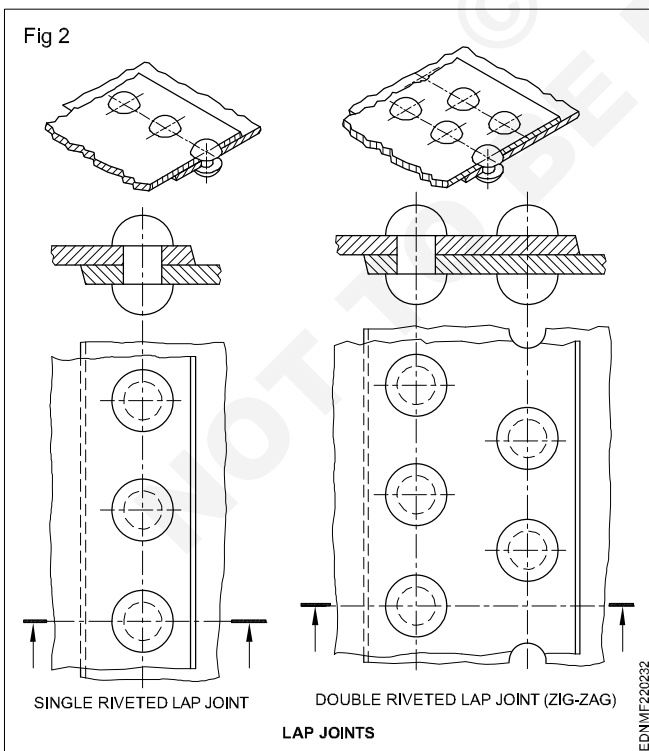

Types of lap joints

Single riveted lap joint: There is only one row of rivets. The plates to be joined are placed one above the other to a lap length of $3d$, d being dia of the rivet.

Riveted joints are named according to the number of rows of rivets, a single riveted lap joint has one row of rivets, double riveted lap joint has two rows of rivets - triple riveted joint has three rows of rivets. The rows may be chain or zig-zag. (Fig 3a & b)

Proportions of riveted joints: The diameter of rivet, pitch and margins are calculated to prevent failure of joint, forming a safe and efficient joint. For all sizes, thickness of the plates is considered first.

- Diameter of rivet $d = 6\sqrt{t}$ called Unwin's rule
- Pitch (Max.) $P = 3d$
- Margin $M = 1.5d$
- Row pitch for chain riveting (P_r) = $2d + 6\text{mm}$
- Row pitch of zig-zag (P_r) = $2d$
- Length of rivet = thickness of plates (plate grip) + $1.25d$ or $1.7d$

Butt joints: When the plates butt against each other the joint is called butt joint. The joint may have either single cover plate or double cover plate and single riveted, double riveted and triple riveted etc. on each plate. These are generally used on longitudinal seams of cylindrical boiler shells etc. (Fig 4)

In butt joint, the thickness of cover plates or strap with respect to plates being joined is

- single strap = t to $1.125t$
- double strap = $0.625t$ to $0.8t$

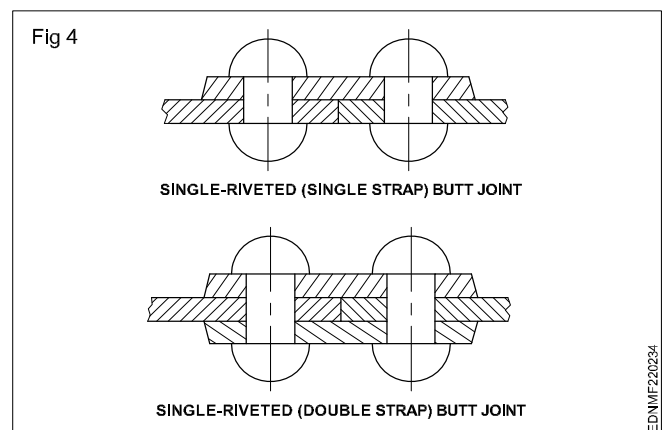

"Chain riveting" and zig-zag riveting: When the rivets in the rows are placed directly opposite to each other it is called chain riveted. (Fig 5a) If rivets are staggered it is called zig-zag riveted. (Fig 5b)

Fig 3

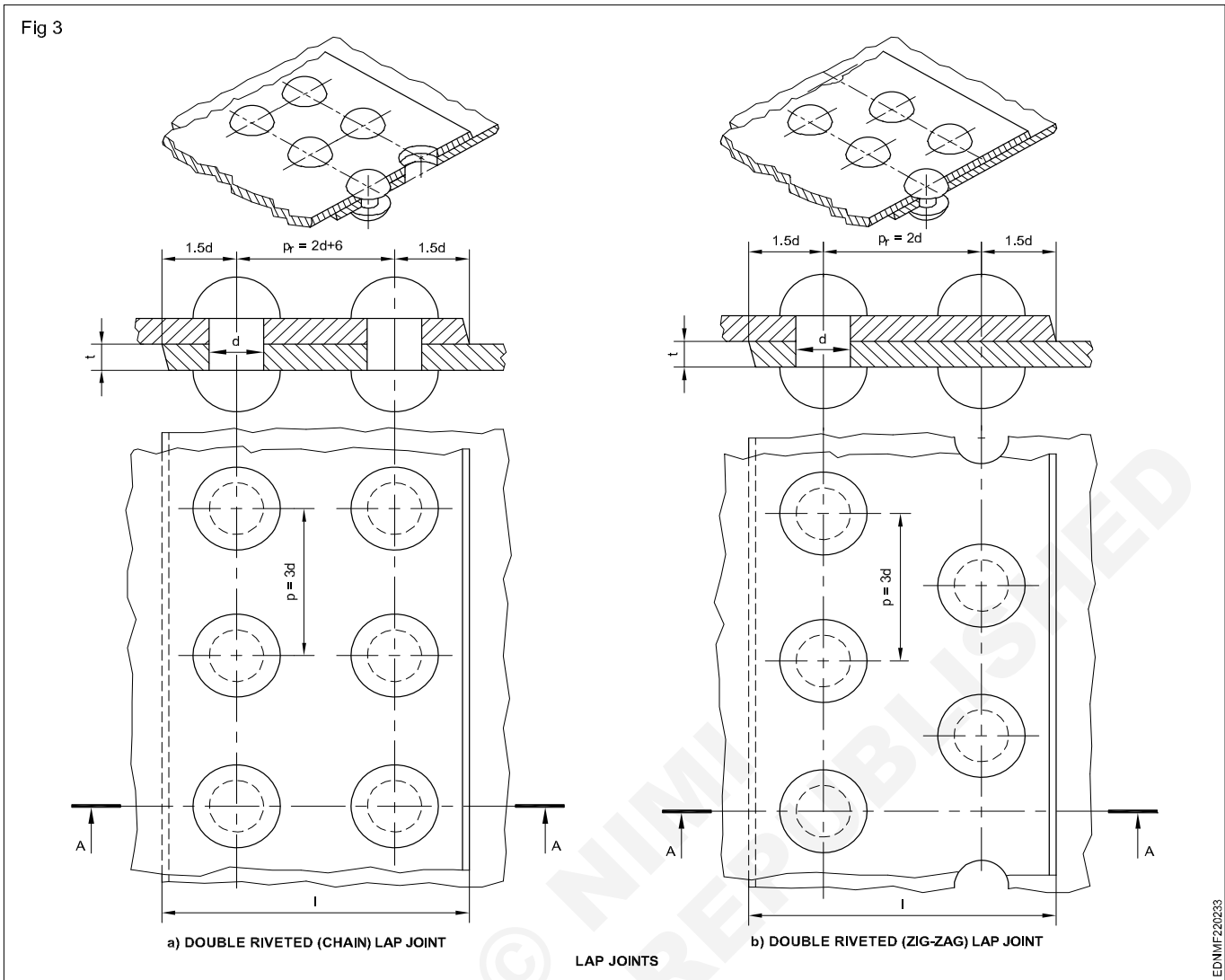

EDNMF220233

The distance between the rows of rivets is called "Row pitch" P_r . The value of row pitch (P_r) in the case of chain riveting is $0.8 P$ and $0.6 P$ for zig-zag riveting.

The distance between the centre of one rivet in one row to the centre of the nearest rivet in the adjoining row is called diagonal pitch - P_d (Fig 5b)

The figures show the double riveted butt joint (zig-zag) double strap.

Caulking and Fullering: (Fig 6) Due to high internal pressure of steam or water in the boiler, there is the possibility of the leakage of steam or water through rivet holes or joint i.e., between plates. To prevent such leakages the rivet heads and plate ends are firmly forced together. It is called caulking and fullering. For caulking a blunt type chisel is used by hammering the rivet head/plates. (Fig 6a)

In fullering a tool with thickness equal to that of plate is used to hammer the edges of the plate. It is used to press the plate ends. (Fig 6b)

Figures 7 show how the plates at right angles can be joined using rivets.

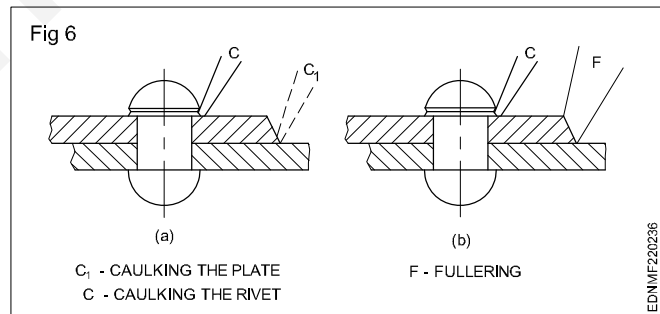

EDNMF220236

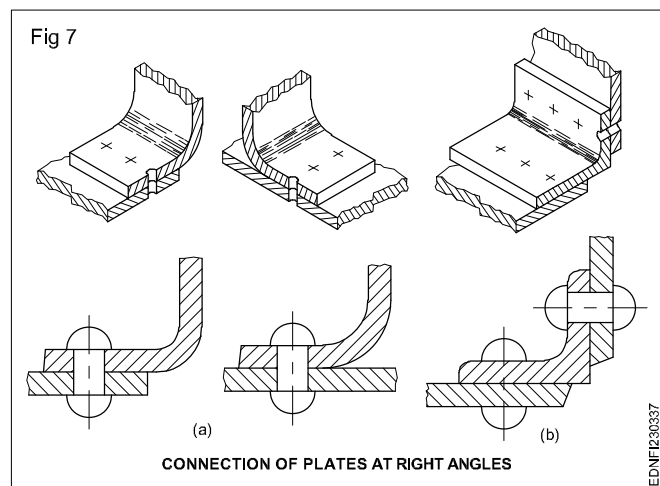

EDNMF230337

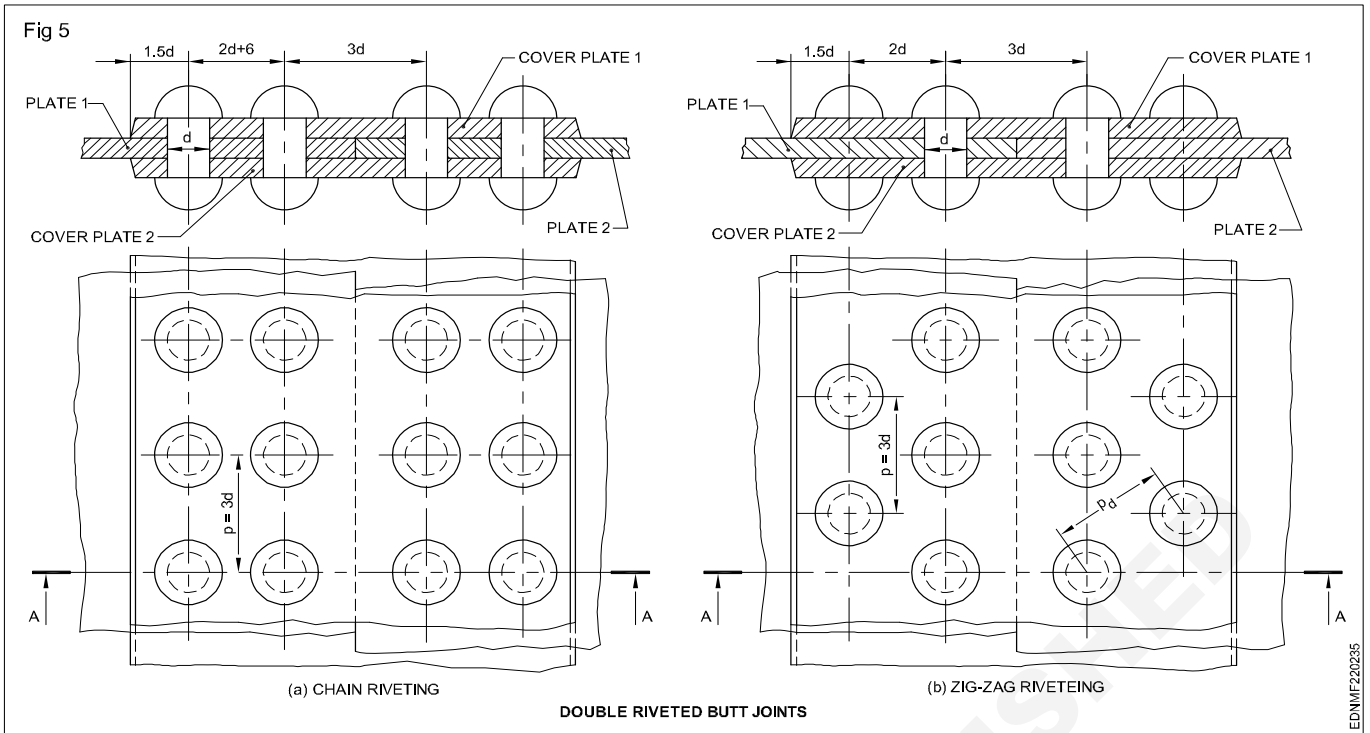

Method of indicating and dimensioning of rivets

Generally rivets are indicated by their centre lines thickened in the direction and at right angles to the seam. (Fig 1)

The Table No. 1 shows the symbols for rivets.

TABLE 1
TABLE OF SYMBOLS FOR RIVETS AND BOLTS
(Clauses 6.3.1.1, and 6.5.3.1)

DESCRIPTION	METHOD OF DRAWING IN	
	VIEW	SECTION
RIVET, GENERAL		
RIVET, COUNTERSUNK ON BACK SIDE		
RIVET, COUNTERSUNK ON FRONT SIDE		
RIVET, COUNTERSUNK ON BACK AND FRONT SIDE		

To distinguish between bolts and rivets in a side view or section, it may be useful to add an arrow (angle about 90°) at each end of the centre line of the bolts/rivets.

In case to nuts for bolts if any, this is marked by double arrow as in Fig 1.

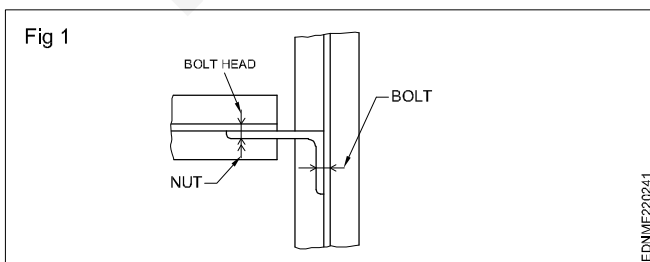

The centre lines for rivets/bolts shall be represented by continuous thin lines. (Fig 2)

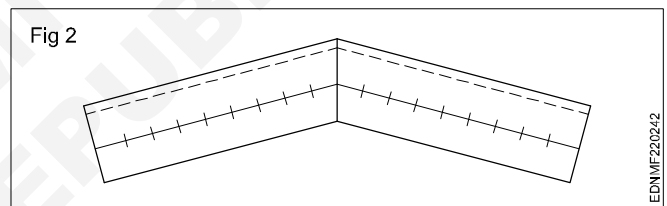

The centre line or the neutral fibre is indicated when necessary by a long chain thin line as shown in Fig 3.

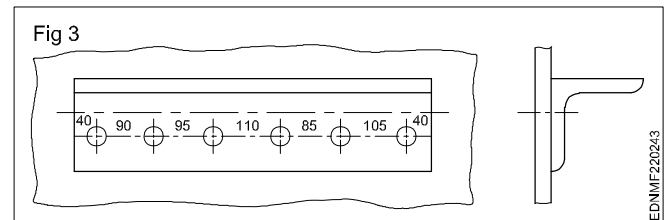

In case of special methods of dimensioning a note should be added to explain to which feature the dimension, refers. For example dimension referred to centre line or dimensions referred to graduation. (Fig 4)

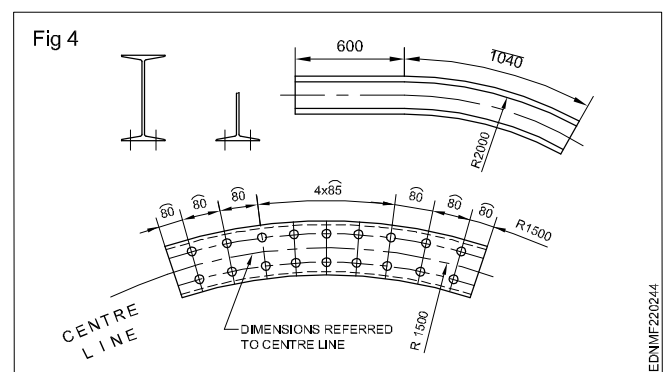

Practice of riveted joints

1 Single riveted lap joint (Fig 1)

Draw a single riveted lap joint, joining 9 mm thick plates. Show minimum 3 rivets.

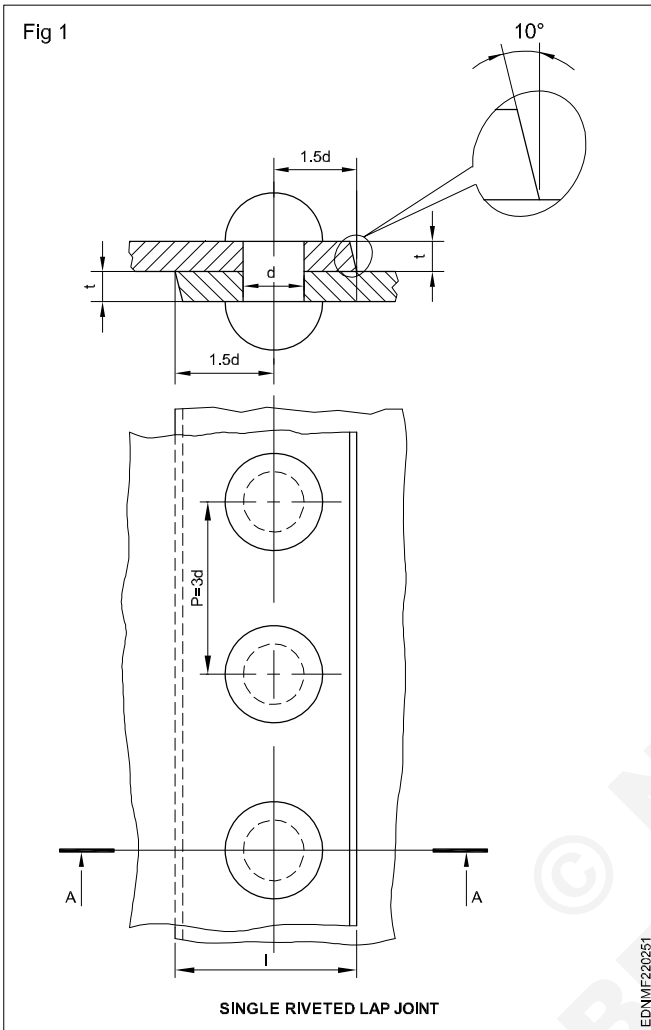

2 Double riveted (chain) lap joint (Fig 2)

Draw a double riveted lap joint/chain riveting with 9 mm thick plates. Show a minimum of 3 rivets.

3 Double riveted (zig-zag) lap joint (Fig 3)

Draw a double riveted zig-zag lap joint, joining 9 mm thick plates.

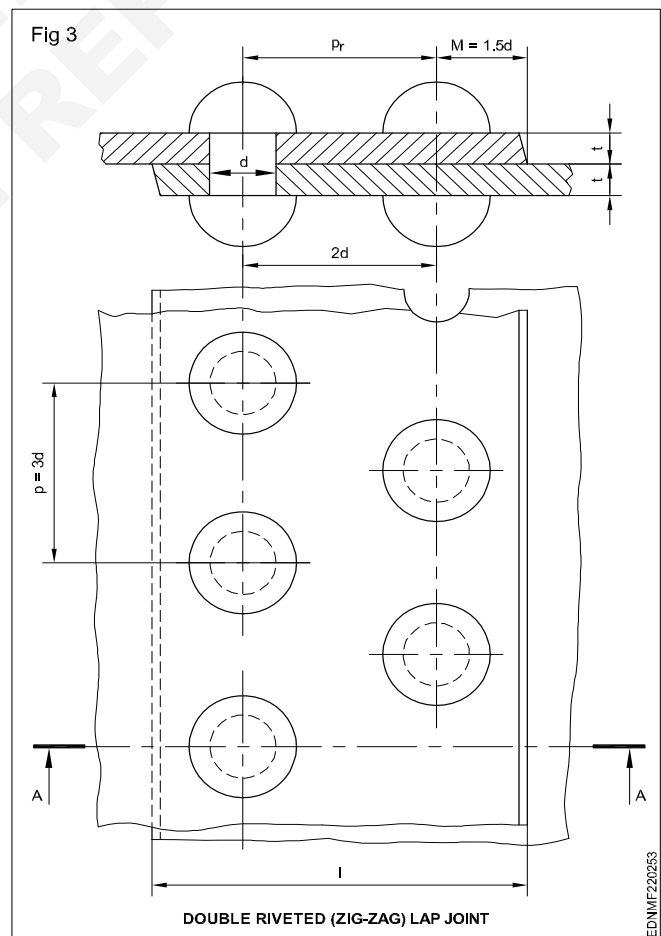
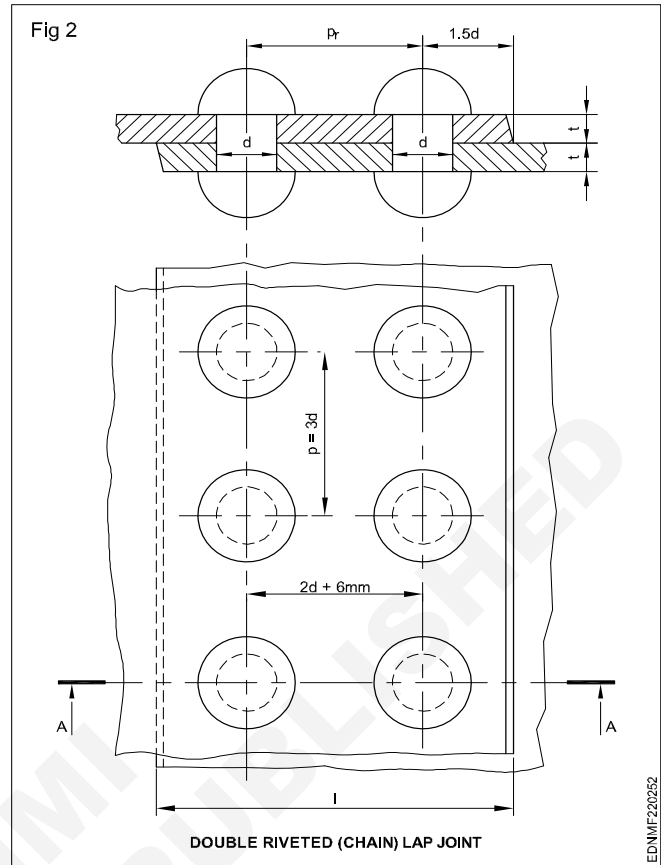

4 Single riveted (Single strap) butt joint (Fig 4)

Draw a single riveted butt joint with single cover plate. Two plates of 9 mm thick butting each other are to be joined by riveting.

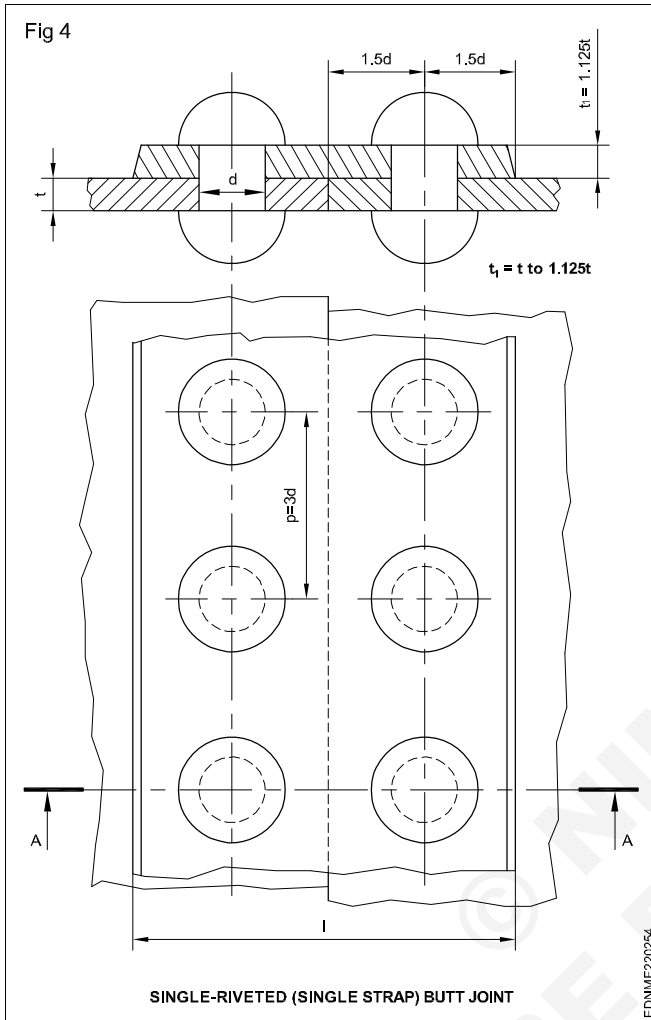

5 Single riveted (Double strap) butt joint (Fig 5)

Draw single riveted double strap butt joint (chain). Plate thickness 9 mm.

6 Double riveted butt joint (chain) (Fig 6)

Draw a double riveted butt joint to join 9 mm thick plates, double cover plates chain riveting.

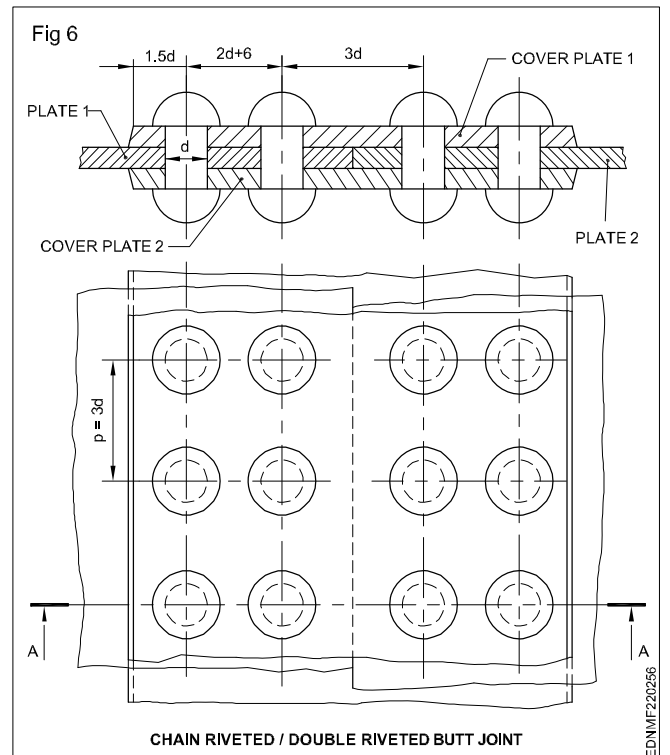
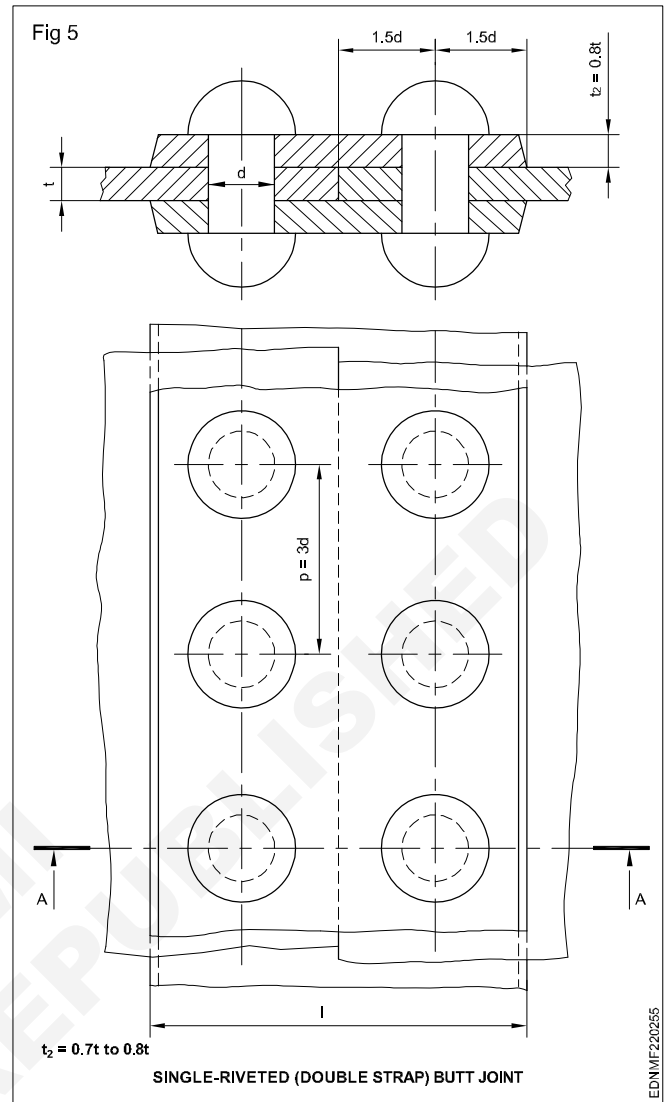

7 Double riveted butt joint (zig-zag) (Fig 7)

Draw a double riveted butt joint to join 9 mm thick plates, double cover plates by zig-zag riveting. (Fig 7)

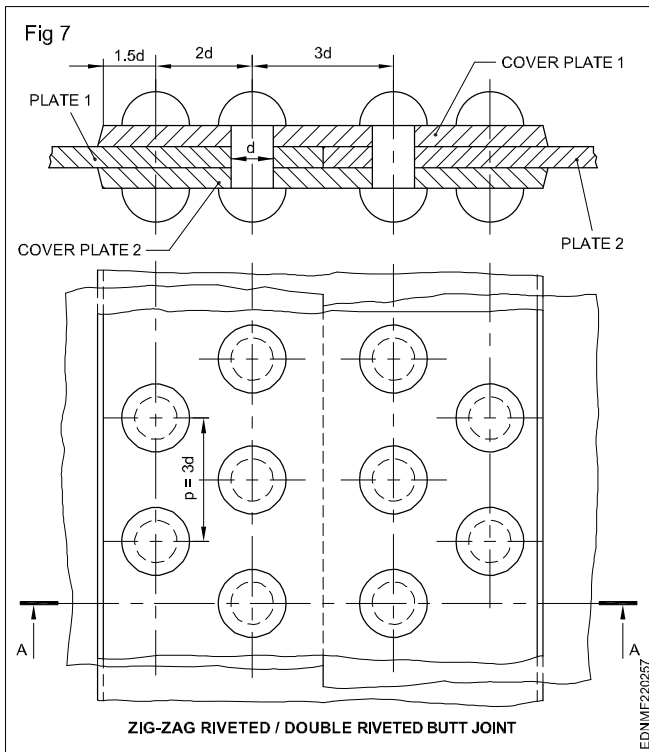

8 Riveted joint with connection plates at right angles (Fig 8)

Draw the riveted joints connecting plates at right angles with a & b bent plate c angle iron, plate thickness 25.

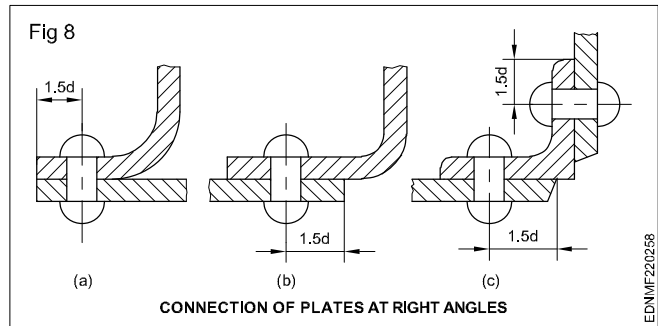

Using bent plate

- Draw the plate bent at radius not less than $2t$.
- Mark the centre of the rivet $1.5d$ from centre of arc.
- Draw the other plate to be riveted and rivet (two methods are shown)
- Show proportions of Fig 8a and 8b.

Using angle plate

- Mark the centre of rivet holes at $1.5d + t$ from the corner of the angle plate.
- Draw the plates, draw the rivets and hatch.
- Show proportions. (Fig 8c)

Welded joints

Different types of welded joints

The 5 basic welded joints are:

- 1 Butt joint
- 2 Corner joint
- 3 Lap joint
- 4 Tee joint and
- 5 Edge joint

Butt Joint (Fig 1):

The joint which is formed by placing the ends of two parts together is called butt joint. In butt joint the two parts are lie on the same plane or side by side. It is the most simplest type of joint used to join metal or plastic parts together.

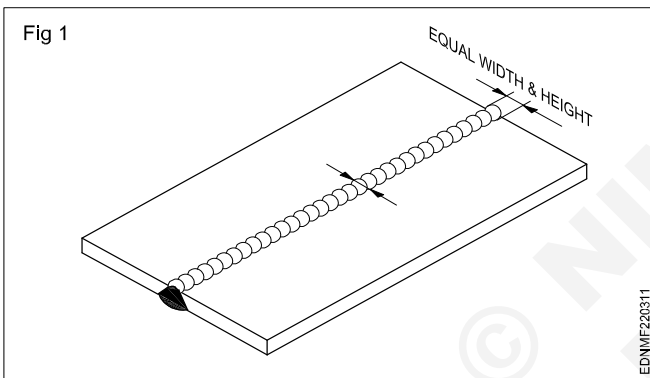

The different weld types in butt joints are:

- i Square Butt weld
- ii Bevel groove weld
- iii V-groove weld
- iv J-groove weld
- v U-groove weld
- vi Flare-V-groove weld
- vii Flare-bevel-groove butt weld

Corner Joint (Fig 2) :

The joint formed by placing the corner of two parts at right angle is called corner joint (see fig above). Two parts which is going to be weld with corner joint forms the shape of L.

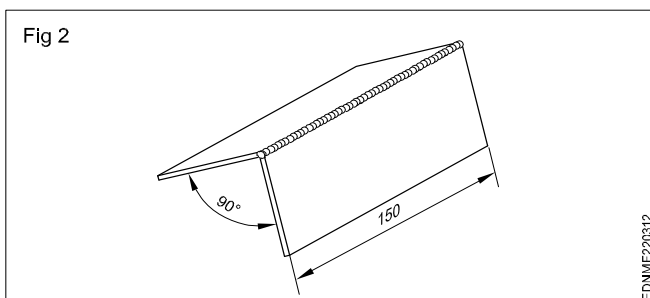

The different weld types in corner joint are as follows:

- i Fillet weld
- ii Spot weld
- iii Square-groove weld or butt weld
- iv V-groove weld
- v Bevel-groove weld
- vi U-groove weld
- vii J-groove weld
- viii Flare-V-groove weld
- ix Edge weld
- x Corner-flange weld

T-Joint (Fig 3):

The joint which is made by intersecting two parts at right angle (i.e at 90 degree) and one part lies at the centre of the other. It is called as T joint as the two part welded look like english letter 'T'.

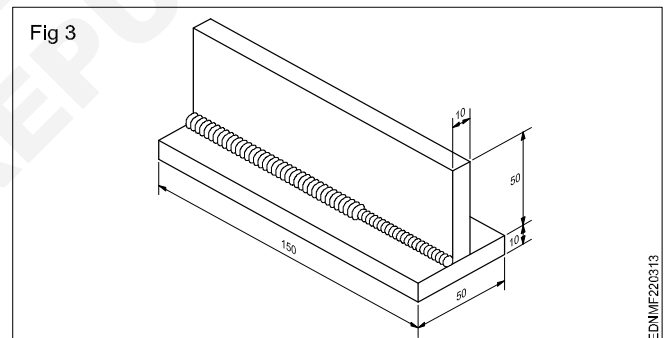

The types of welds in T joint are as follows:

- i Fillet weld
- ii Plug weld
- iii Slot weld
- iv Bevel-groove weld
- v J-groove weld
- vi Flare-bevel groove
- vii Melt-through weld

Lap Joint (Fig 4):

The lap joint is formed when the two parts are placed one over another and then welded (see fig 4). It may one sided or double sided. This types of welding joints are mostly used to join two pieces with different thickness.

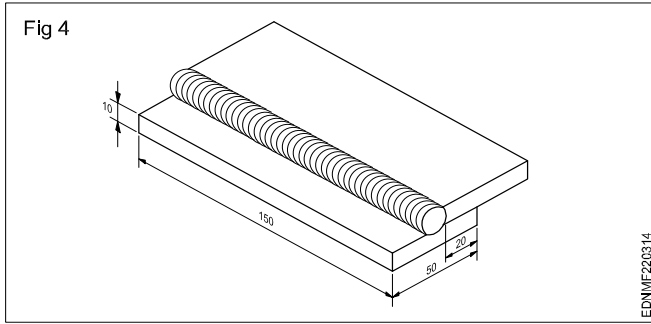

The Various weld types in lap joint are:

- i Fillet weld
- ii Bevel-groove weld
- iii J-groove weld
- iv Plug weld
- v Slot weld
- vi Spot weld
- vii Flare-bevel-groove weld

Edge Joint (Fig 5):

The joint formed by welding the edges of two parts together are called edge joint. This joint is used where the edges of two sheets are adjacent and are approximately parallel planes at the point of welding. In this joint the weld does not penetrates completely the thickness of joint, so it can not be used in stress and pressure application.

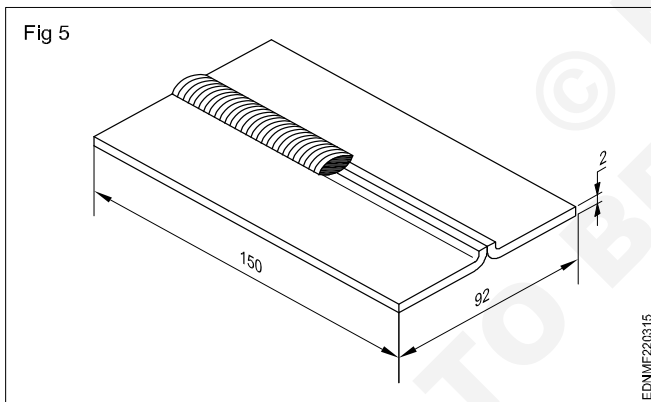

The various weld types in this welding joint are:

- i Square-groove weld or butt weld
- ii Bevel-groove weld
- iii V-groove weld
- iv J-groove weld
- v U-groove weld
- vi Edge-flange weld
- vii Corner-flange weld

Convention used for Welded joints

S.no	Designation	Illustration	Symbol
1	Fillet		
2	Square butt		
3	Single V-butt		
4	Double V-butt		
5	Single U-butt		
6	Double U-butt		
7	Single bevel butt		
8	Double bevel butt		
9	Single J-butt		
10	Double J-butt		
11	Stud		
12	Bead edge or seal		
13	Sealing run		
14	Spot		
15	Seam		
16	Stitch		
17	Plug weld		

Reading of drawing of pipes and pipe joints

Pipe layouts and joints

Pipes are used for carrying fluids, such as water, steam, oil, gas, etc. from one place to another. Circular pipe made cast iron, steel, copper, aluminium, plastic, cement etc. are used for this purpose. Joining of pipes and their fittings for making required layout can be made by different methods and the process is named plumbing. Commonly used pipe joints, the pipe specials and the drawing method of piping layouts using symbols are discussed in this chapter.

Pipe Joints

A pipe is a tube and generally considered as circular in cross-section in engineering practice, pipes are assumed to be straight and stiff, and are available in standard lengths. At the same time, a tube is assumed as flexible pipe and available in coil form. The size of a pipe is designated by its inner diameter and thickness. Pipes are joined by many methods (Fig 1) and they are named as

- a Screwed pipe joint
- b Welded pipe joint
- c Flanged pipe joint
 - i Integral flanges

- ii Screwed flanges
- d Glued or cemented pipe joint
- e Soldered pipe joint

Pipe fittings or specials

To connect two pipes together and to make branches, reduction or increase of diameter, etc. different parts of a pipeline called pipe fittings or specials are used. Screwed pipe specials commonly used in plumbing are shown in Fig 2. The screw threads used on pipe fittings are of fine size in pitch and slightly different from the standards threads for nuts and bolts. The size values are available in engineering tables.

Depending on the shape and purpose, the joints commonly used are classified into the following categories:

- 1 Socket and spigot joint
- 2 Screwed union joint
- 3 Integral flanged pipe joint (Integral or screwed)
- 4 Hydraulic (Armstrong) pipe joint
- 5 Expansion joints

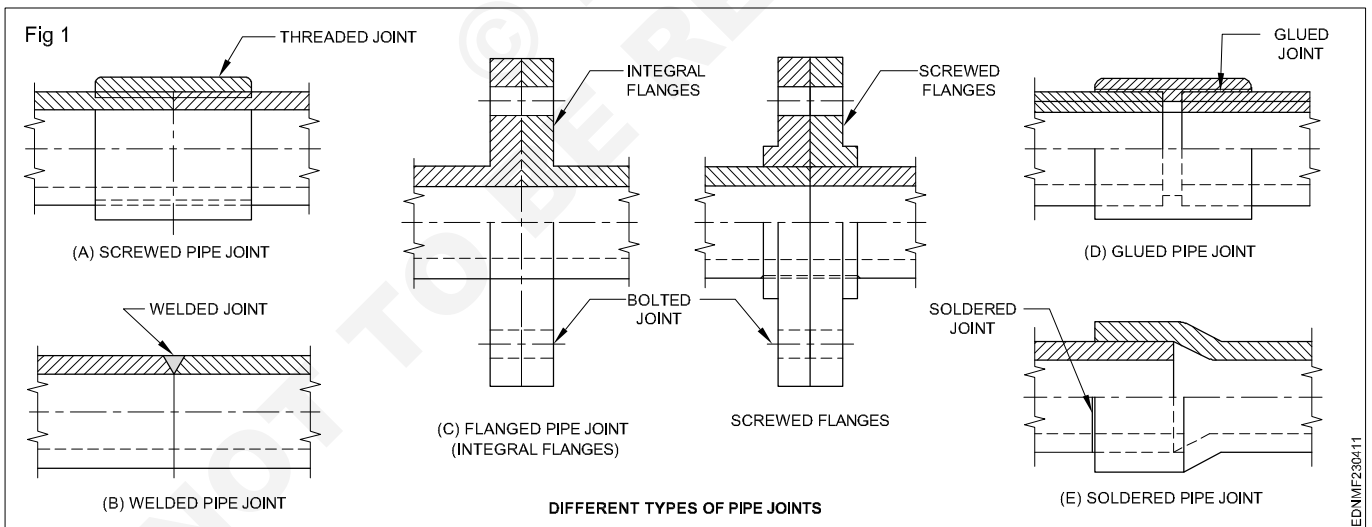

EDNMF230411

Fig 2

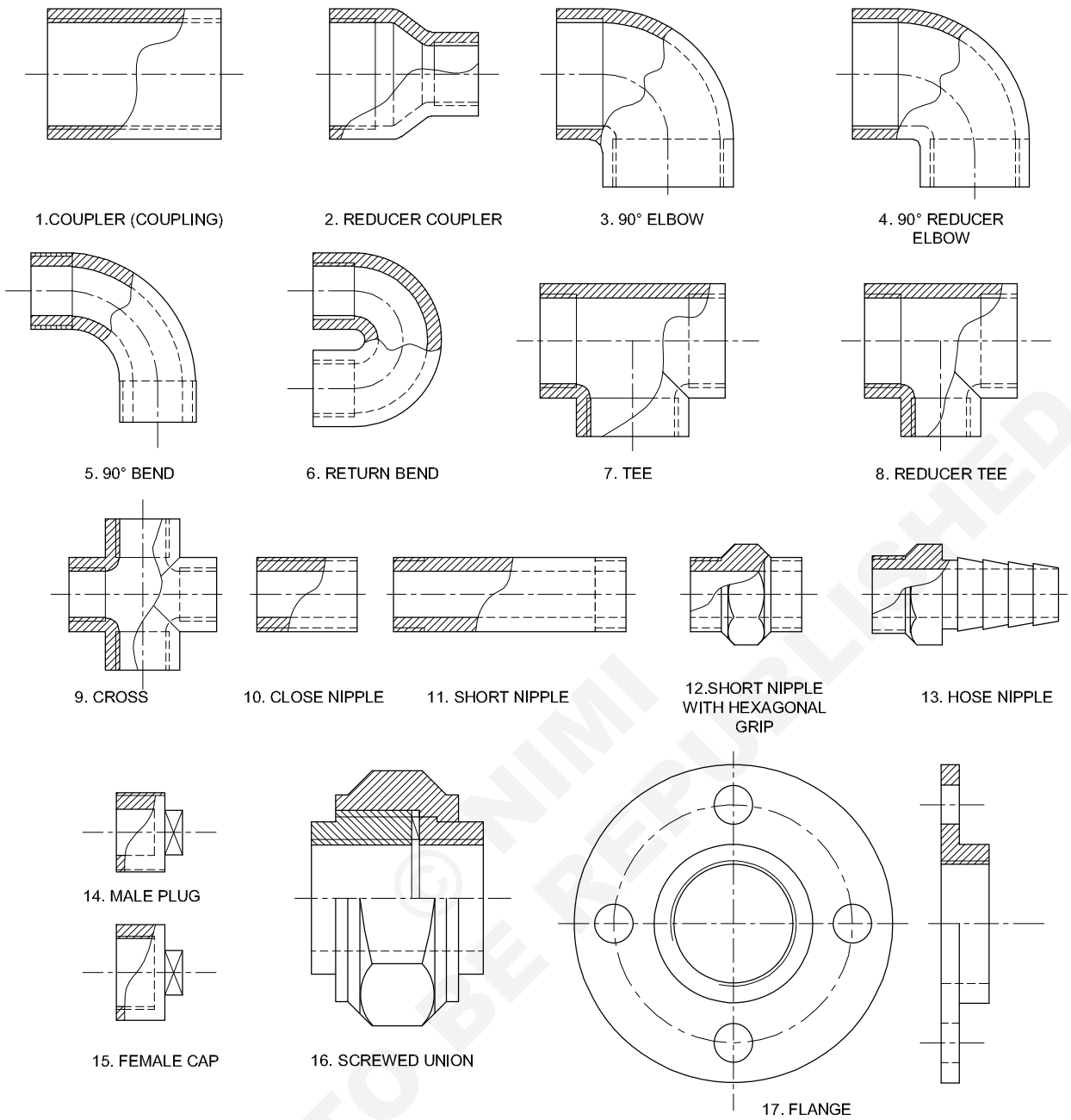

PIPE FITTINGS

EDNMF230412

Piping layout drawings

Piping layout drawings can be classified into the following categories:

- 1 Double line isometric layout
- 2 Single line isometric layout

- 3 Double line orthographic layout
- 4 Single line orthographic layout
- 5 Single line developed layout

In double line piping layouts, all the pipe are represented by two lines and fittings as shown in Fig 3.

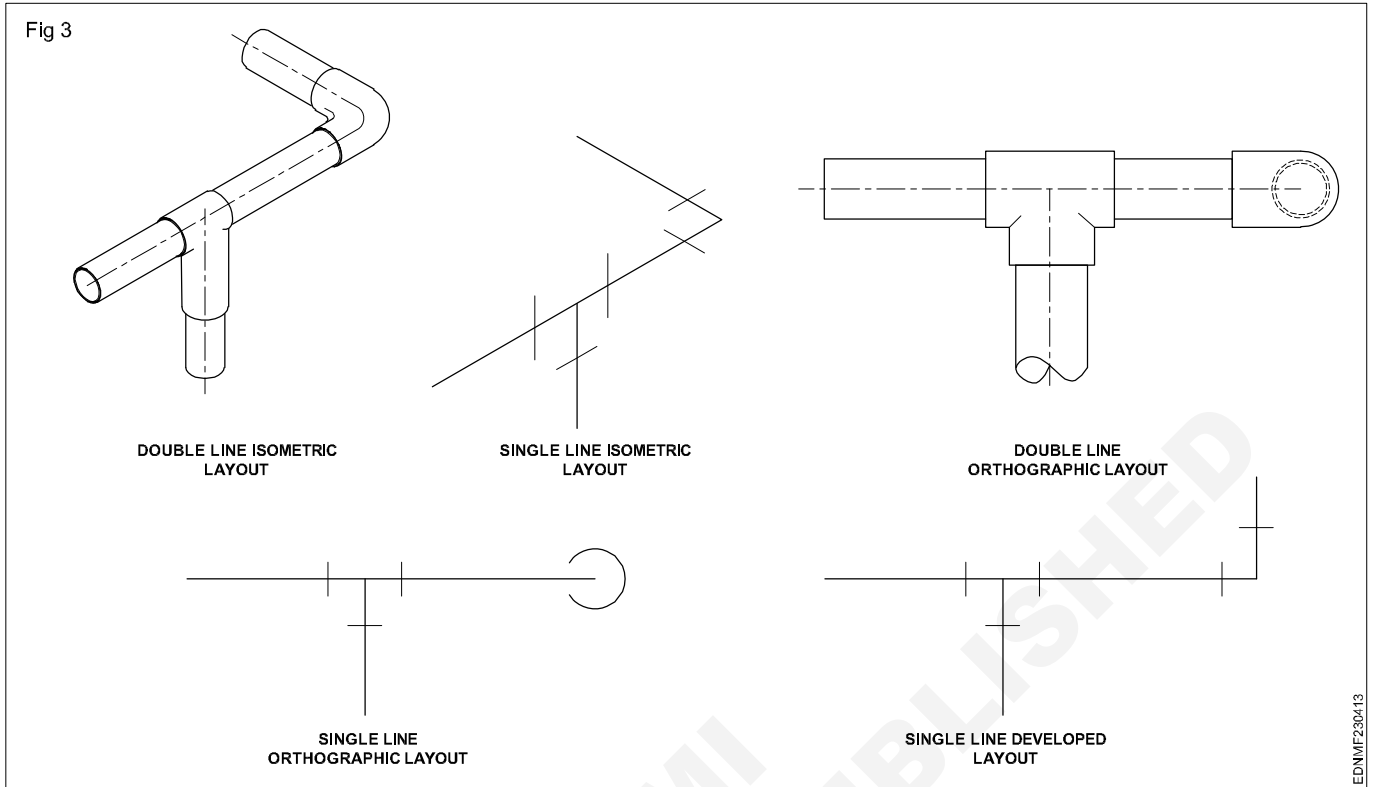

Elbows (Fig 4)

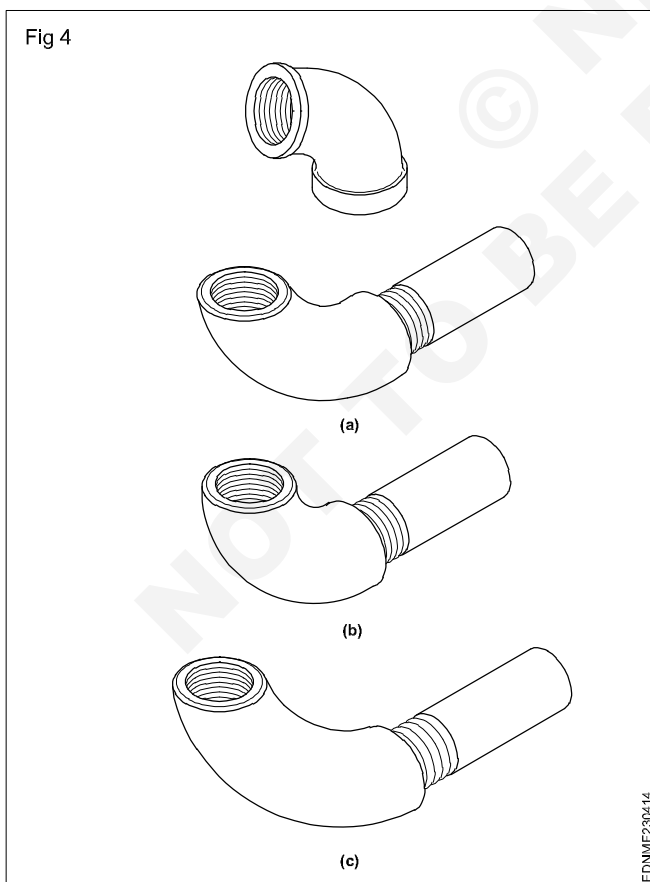

Tee branch (Fig 5)

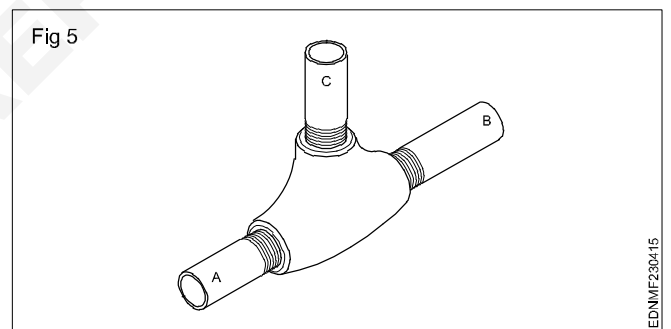

Reducing tee branch (Fig 6)

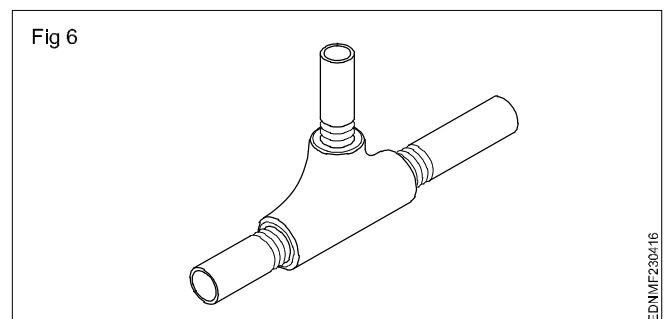

Eccentric reducer (Fig 7)

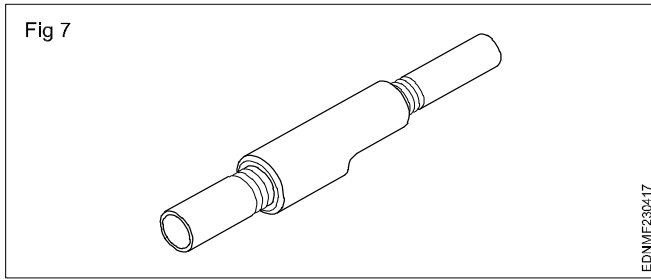

Concentric reducer (Fig 8)

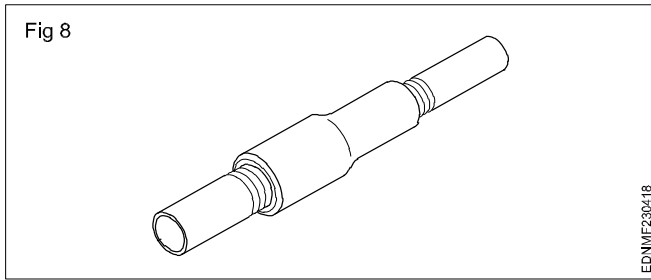

Cap (Fig 9)

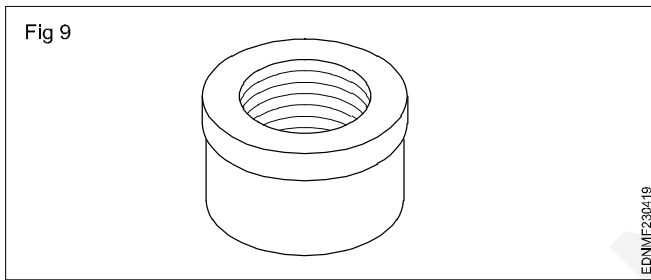

Plug (Fig 10)

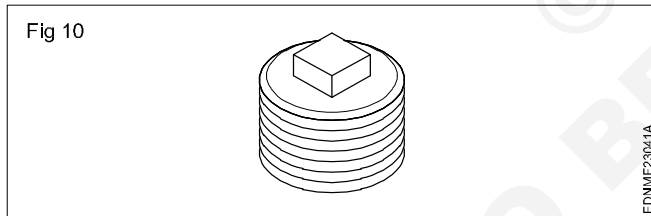

Coupling (Fig 11)

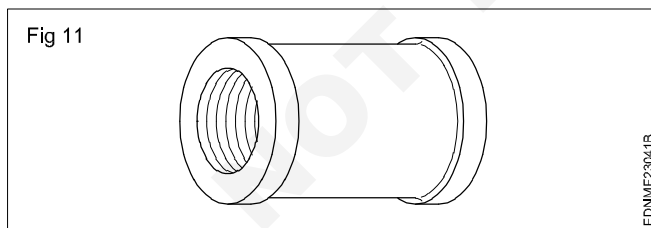

Reducer (Fig 12)

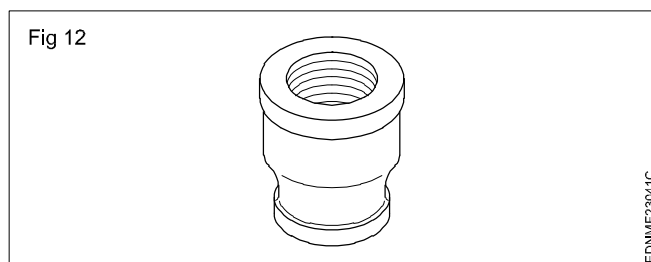

Union (Fig 13)

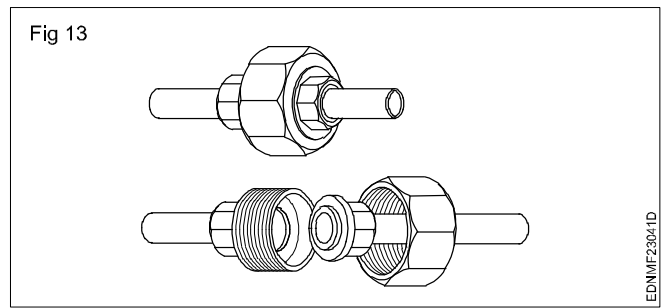

Close nipple (Fig 14)

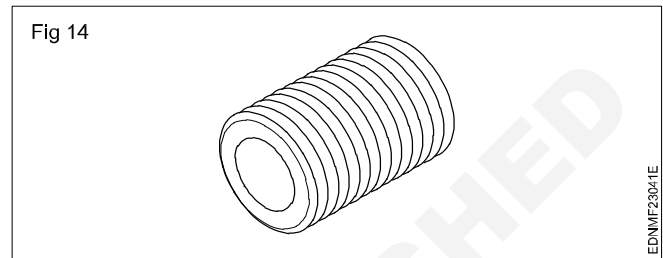

Short nipple (Fig 15)

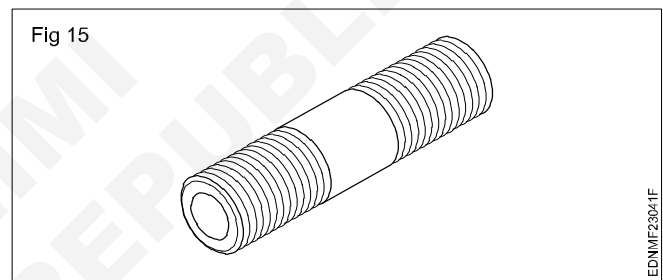

Long nipple (Fig 16)

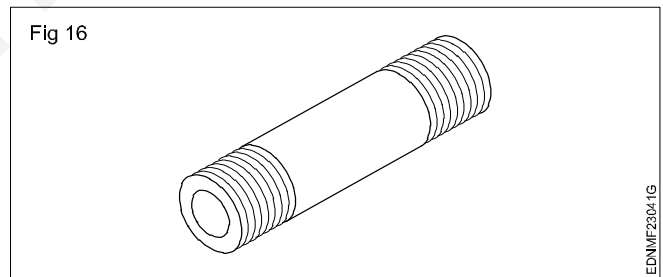

Pipe threads (Fig 17)

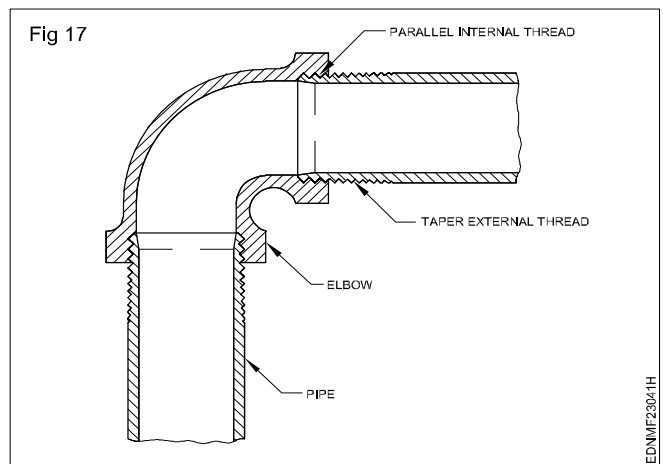
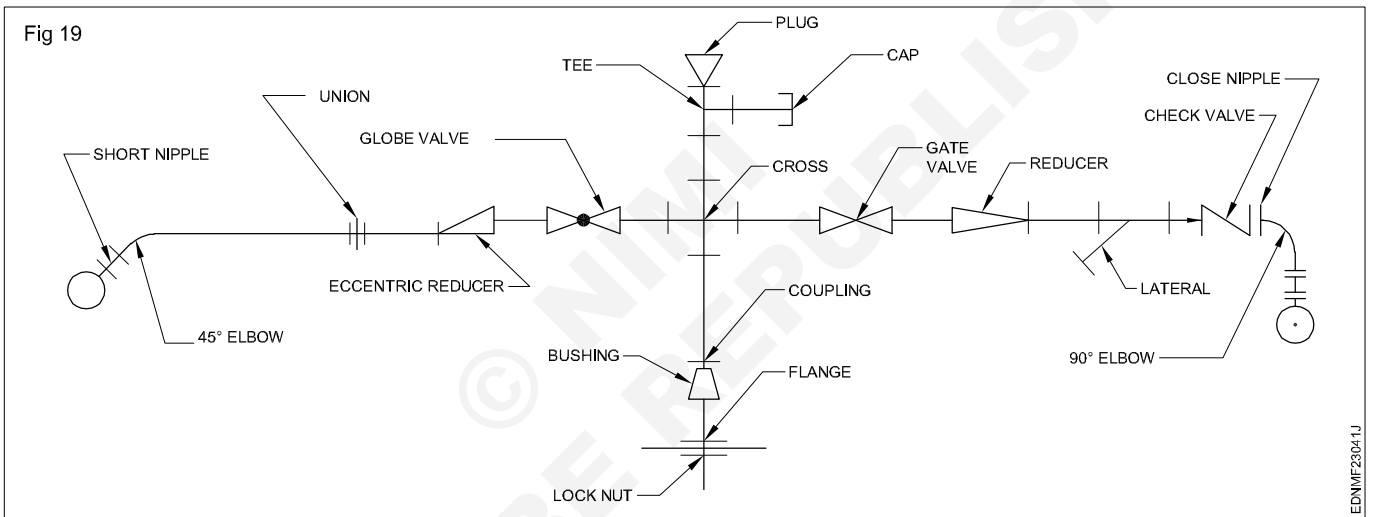
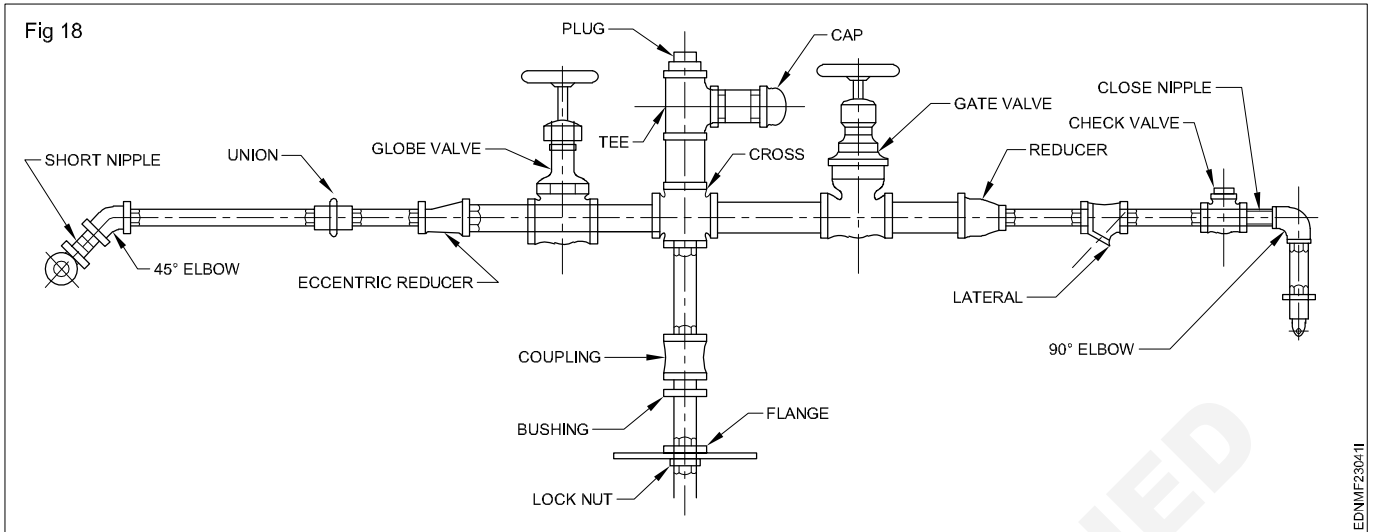

Fig 18 shows the double line orthographic view of a piping layout and Fig 19 shows the converting this piping layout into single line orthographic view.



Reading of job drawing & assembly view

Reading of Ship equipment diagram - Structure of Single Arm Davit

Single-arm davit main components: davit arm, pedestal, slewing bearing, slewing tray, hydraulic slewing unit, hoisting mechanism, guide tackle, boat fall and its accessory, remote control unit, limit unit, hydraulic system and electrical parts, etc., (Fig 1)

- | | |
|-------------------------------|----------------|
| 1 Davitarm | 2 Pedestal |
| 3 Slewing bearing | 4 Slewing tray |
| 5 Hydraulic slewing unit | |
| 6 Hoisting mechanism | |
| 7 Guide tackle | |
| 8 Boat fall and its accessory | |
| 9 Limit switch unit | |
| 10 Remote control rope unit | |
| 11 Hydraulic system | |
| 12 Electrical system | |

- 1 Davit arm:** It is a main active structure member of the appliance, and can be used for slewing the davit arm.
- 2 Pedestal:** It is the base of the appliance to bear force, welded on deck. Using bolts to connect single davit arm and slewing tray and slewing bearing.
- 3 Slewing bearing:** A special bearing used to support slewing tray and slew.
- 4 The slewing tray:** An assembly part connecting the davit arm and slewing bearings. It can effectively slew the davit arm to outboard position or to stowed position through the hydraulic slewing device.
- 5 Hydraulic slewing unit:** A drive device used to slew davit, consist of hydraulic motor, wet sheet hydraulic brakes, planetary reducer, small gear, and other components.
- 6 Hoisting mechanism:** used for lifting rescue boat or life raft, consist of electrical motor, reducer box, one-way clutch gear, speed limit clutch unit, handle unit, and so on.

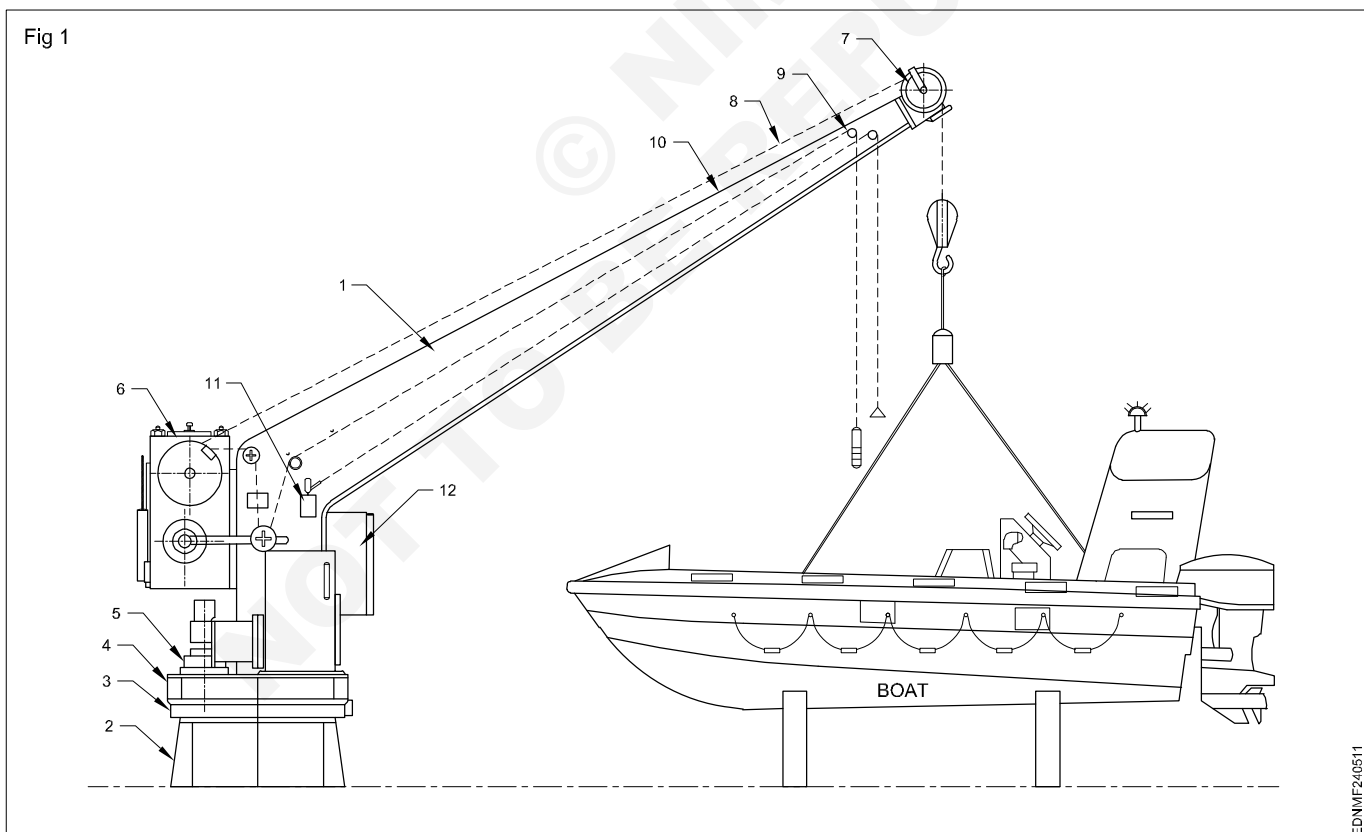

Read and write the following parts of Single Arm Davit. (Fig 1)

- | | |
|-------------------|---------------------|
| a Davitarm | c Limit switch unit |
| b Slewing bearing | d Guide tackle |

Pivot Type Davit (Fig 2)

Reading of pivot type davit

View of davit, showing lifeboat in the stowed and swung-out positions.

- 1 Winch-brake remote-release cable,
- 2 Sheave
- 3 Horn on davit
- 4 Floating block

- 5 Davit
- 6 Suspension ring
- 7 Bollard on lifeboat
- 8 Gripe
- 9 Falls
- 10 Winch-brake handle
- 11 Winch drum
- 12 Davit hinge.

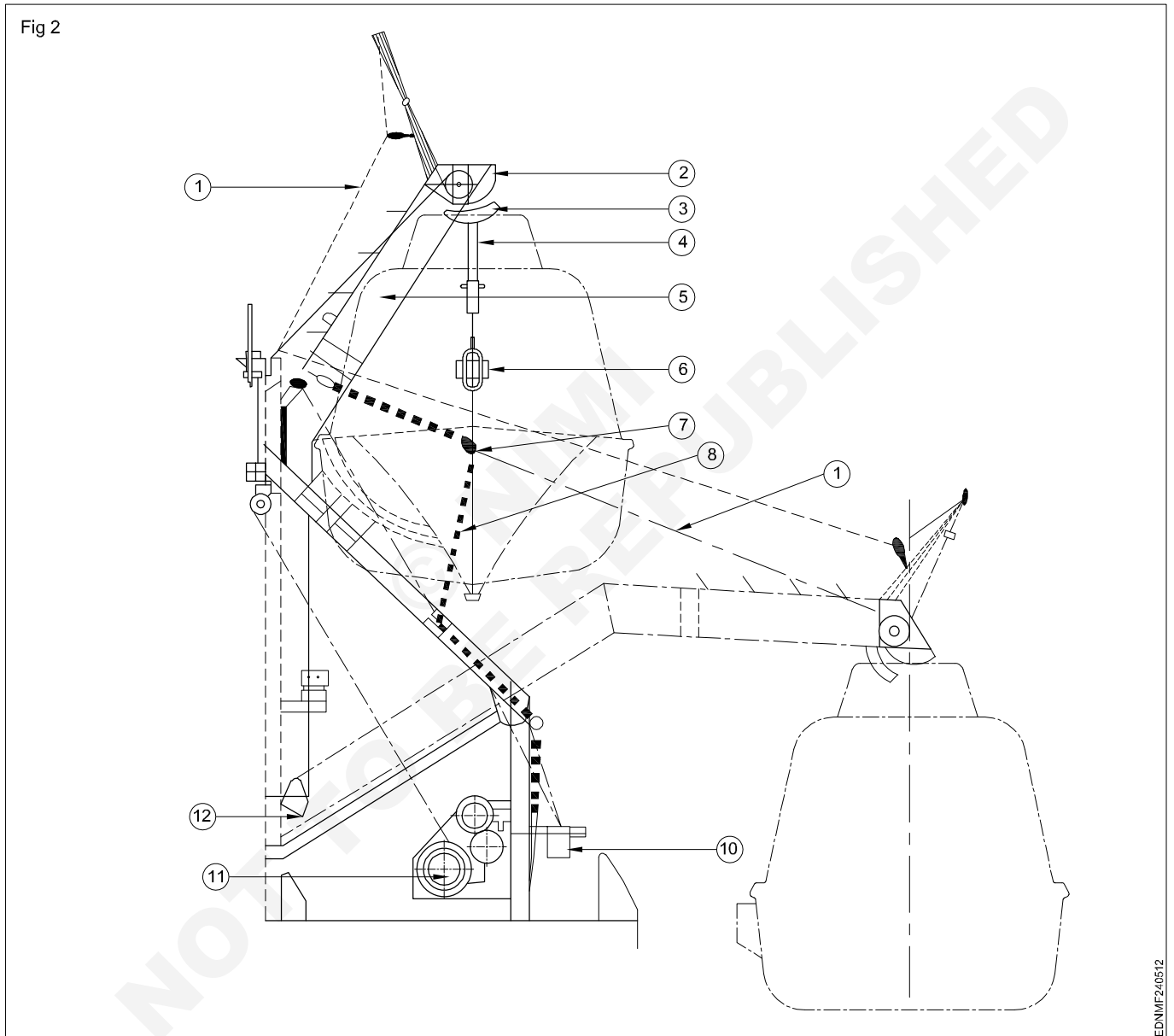

Read and write the following (Fig 2)

- 1 What is the function of pivot type davit?
- 2 What is the use of suspension ring?
- 3 Write the name of the drum.

Diagram of Rescue Boat Release Hook (Fig 3)

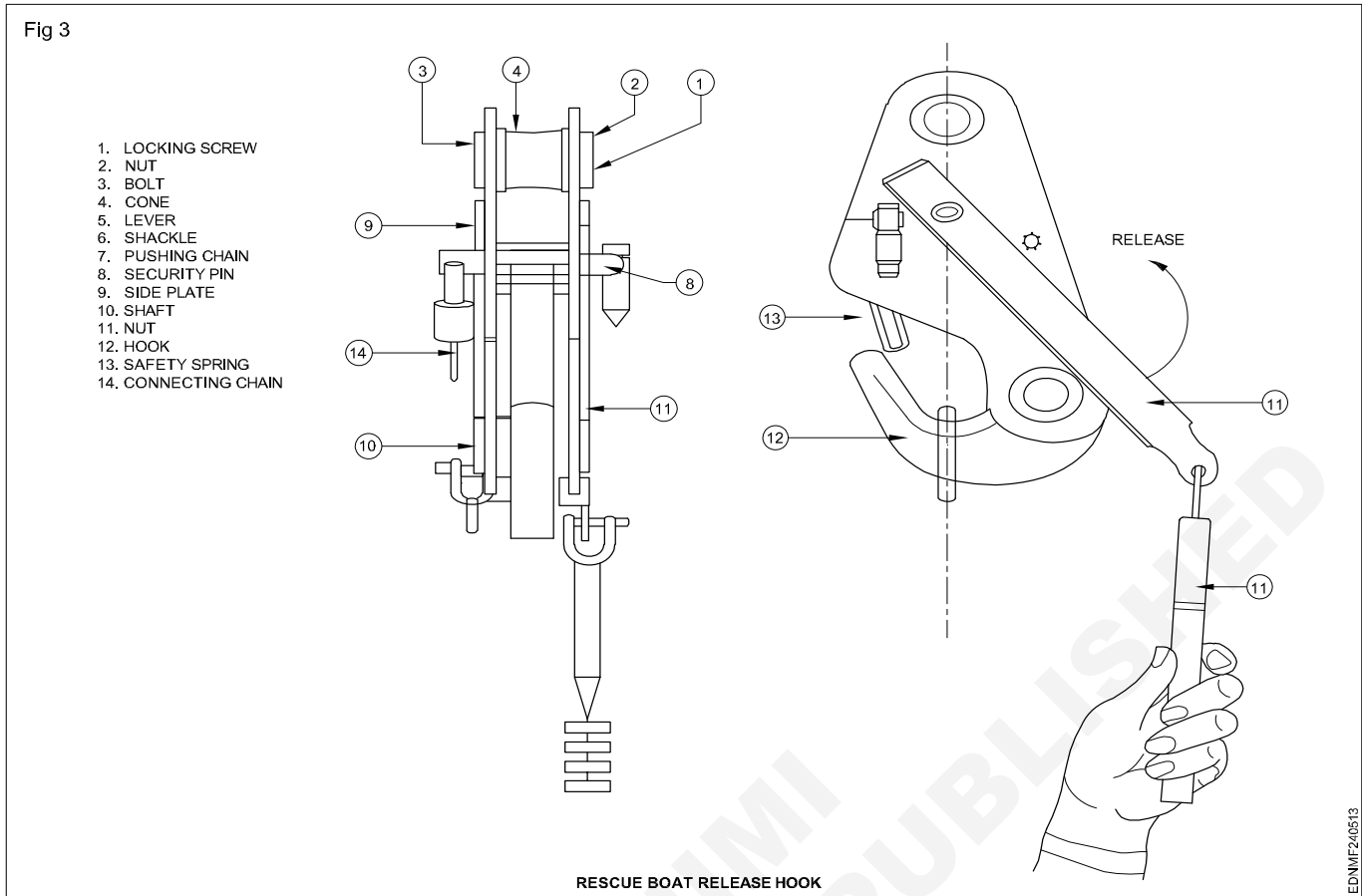

Read and write the following (Fig 3)

1 Write the use of boat release hook.

2 Write the name of the mechanism the hook is working.

Reading of Chain Pulley Block (Fig 4)

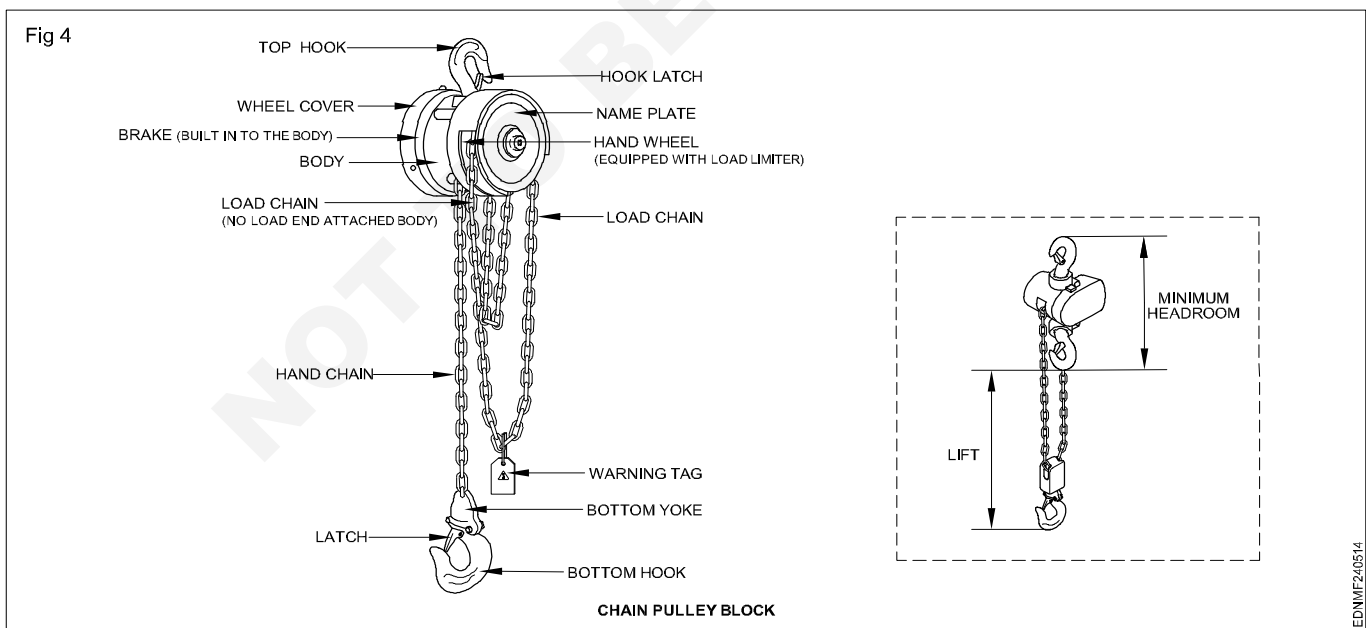

Read and write the functions of the following parts.

1 Brake

3 Hand wheel

2 Hook latch

Assembly drawing of falling block (Fig 5)

1 Read and understand the given Assembly drawing and its parts.

Fig 5

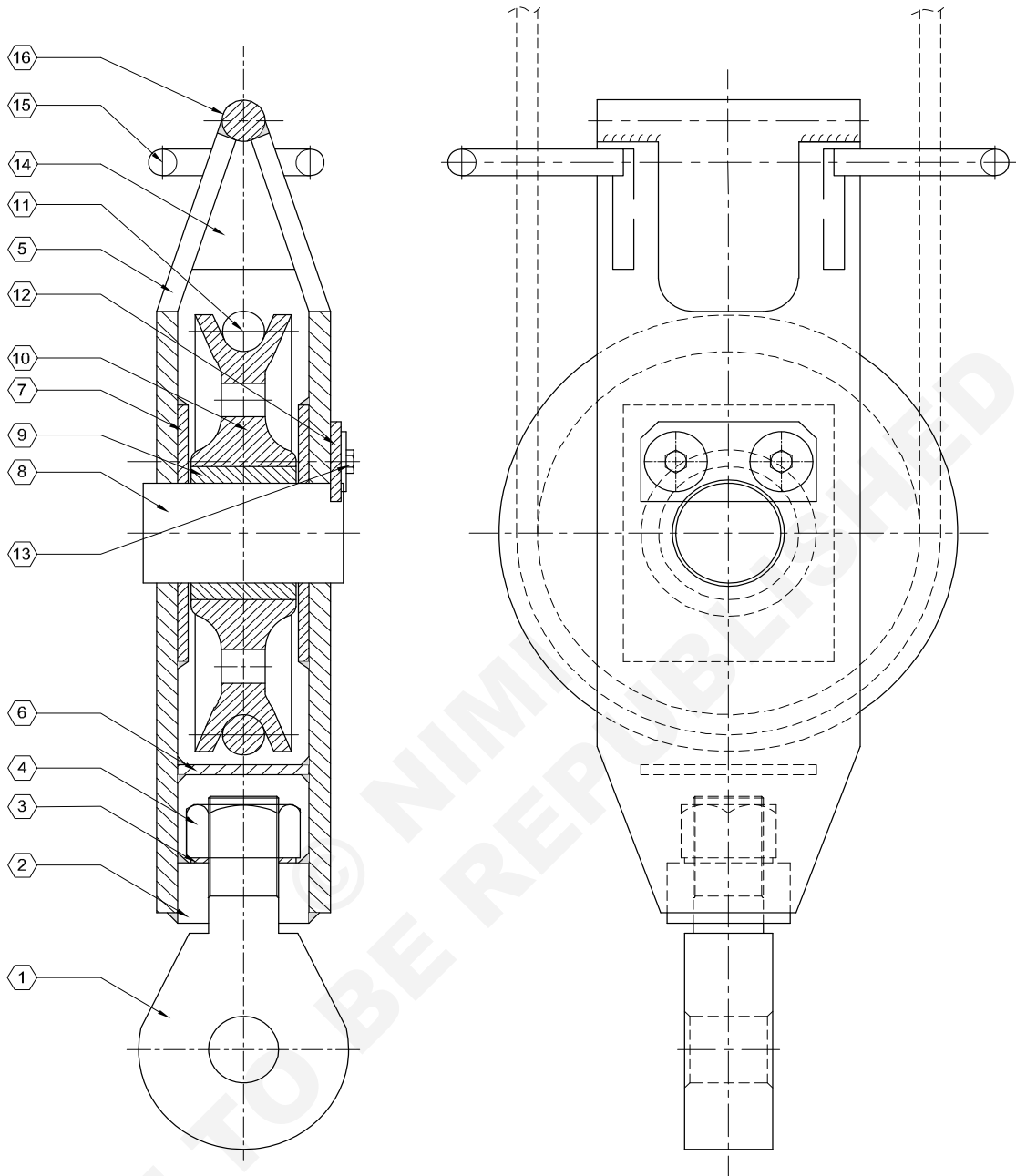

S.NO	DESCRIPTION NAME	MATERIAL	QUANTITY	STOCK SIZE	REMARKS
1	EYE BOLT	IS 226	1	60 x 220 x 50 Thk.	
2	BOTTOM	IS 226	1	75 x 70 x 36 Thk.	
3	WASHER	IS 226	1	ID - 42, OD - 60 x 3 Thk.	
4	HEX NUT	STD	1	M 40	
5	SIDE FRAME	IS 226	2	459 x 150 x 12 Thk.	
6	INTERMEDIATE GUSSET	IS 226	1	75 x 100 x 6 Thk.	
7	SIDE WEAR PLATE	IS 226	2	154 x 120 x 50 Thk.	
8	SHEAVE PIN	IS 304	1	114 x Ø 60	
9	BUSH	PHOSPHOR BRONZE	1	Ø 80 x 60	
10	SHEAVE	IS 226 STEEL CASTING	1	Ø 262 x 60 Thk.	
11	WIDE ROPE	6/3 GALVANIZED		Ø 22 x 45 mtrs	
12	LOCK PLATE	IS 226	1	100 x 48 x 6 Thk.	
13	HEX BOLT WITH WASHER	STD	1 (EACH)	M 12	
14	GUSSET	IS 226	2	72 x 54 x 12 Thk.	
15	GUIDE FOR WIRE ROPE	IS 226	2	Ø 60 x 100 Long	
16	TOP ROPE PIN	IS 226	1	Ø 25 x 150 Long	

FALLING BLOCK ASSEMBLY

Reading of the component drawings

Read and write the following (Fig 6)

1 How many spline's are there?

2 What is the outer diameter of the gear coupling?

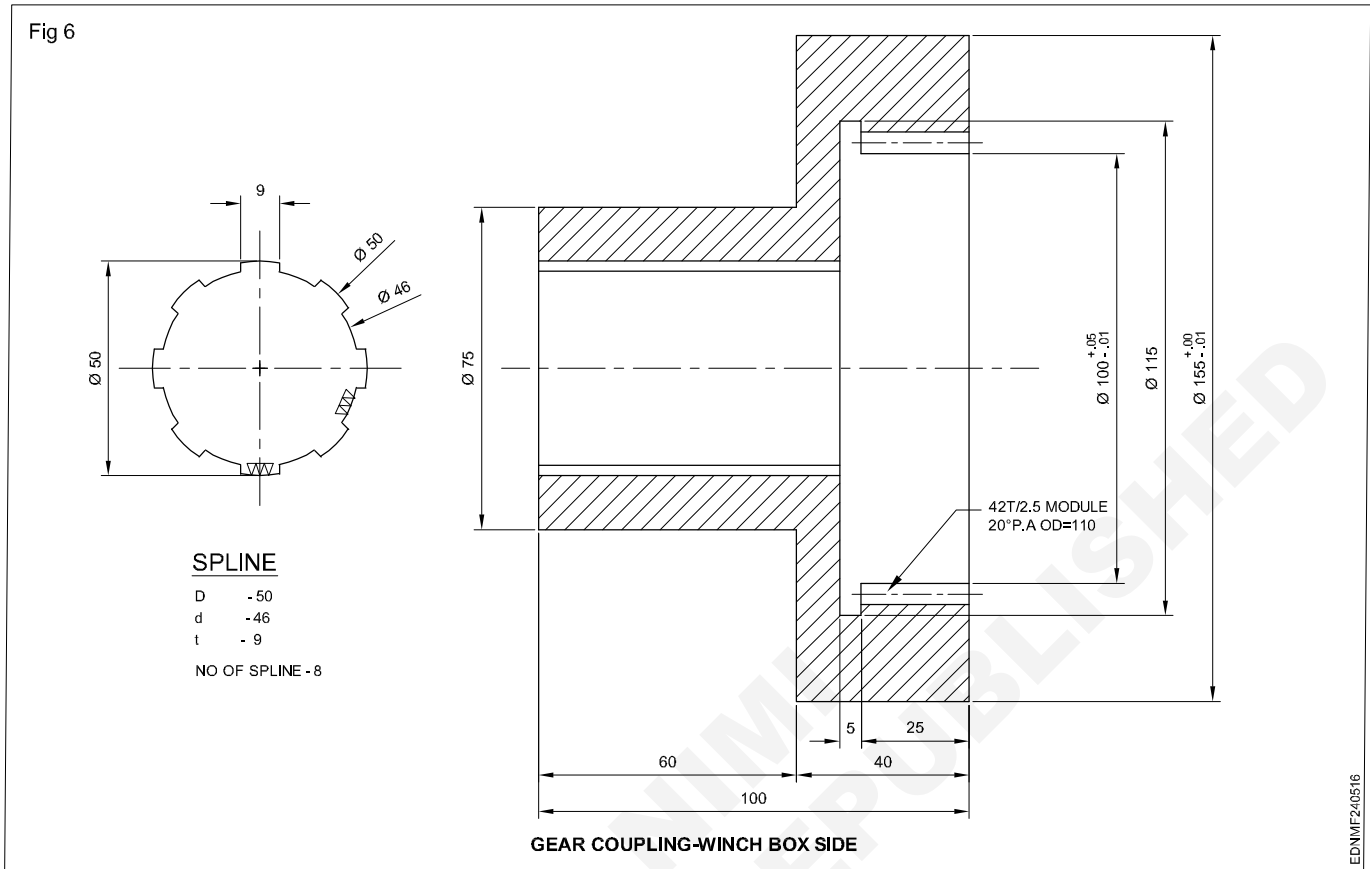

Read and write the following (Fig 7)

1 What is the key way size?

3 What is the bore diameter?

2 Write the number of teeth of the given coupling gear.

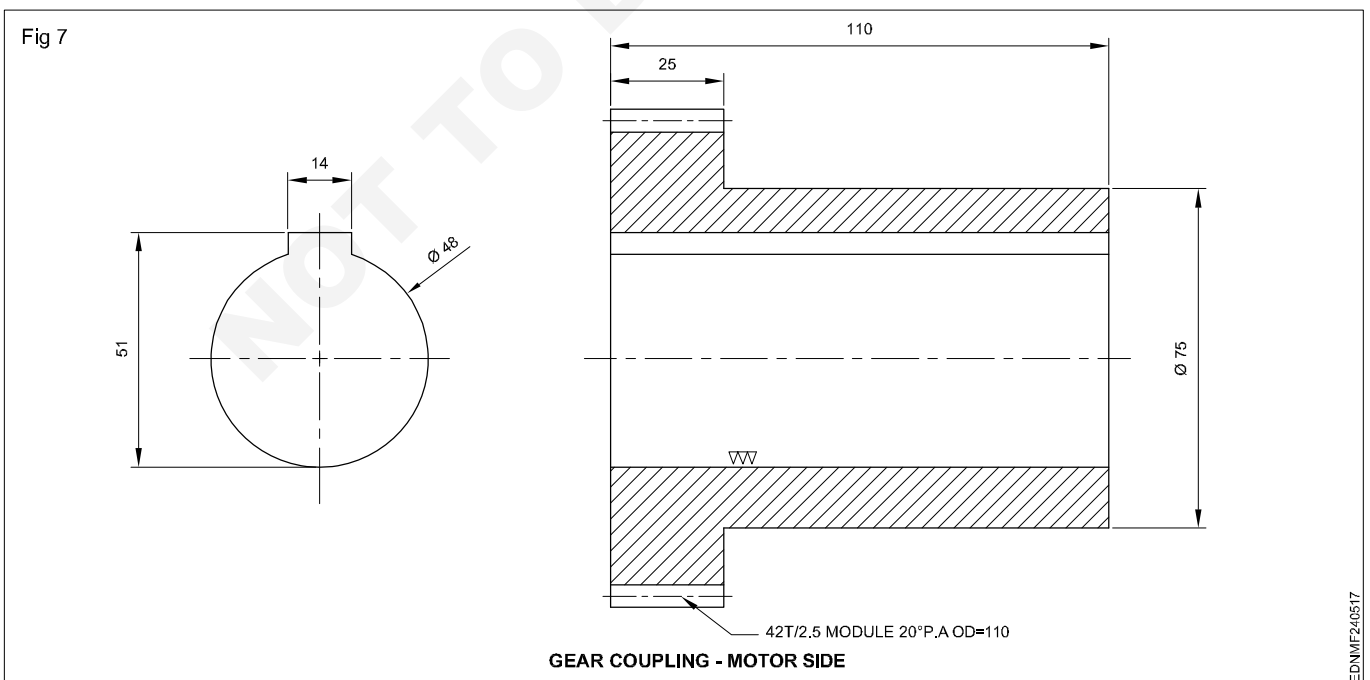

Read and write the following (Fig 8)

- 1 How many holes are there?
- 2 What is the total length of the given component?

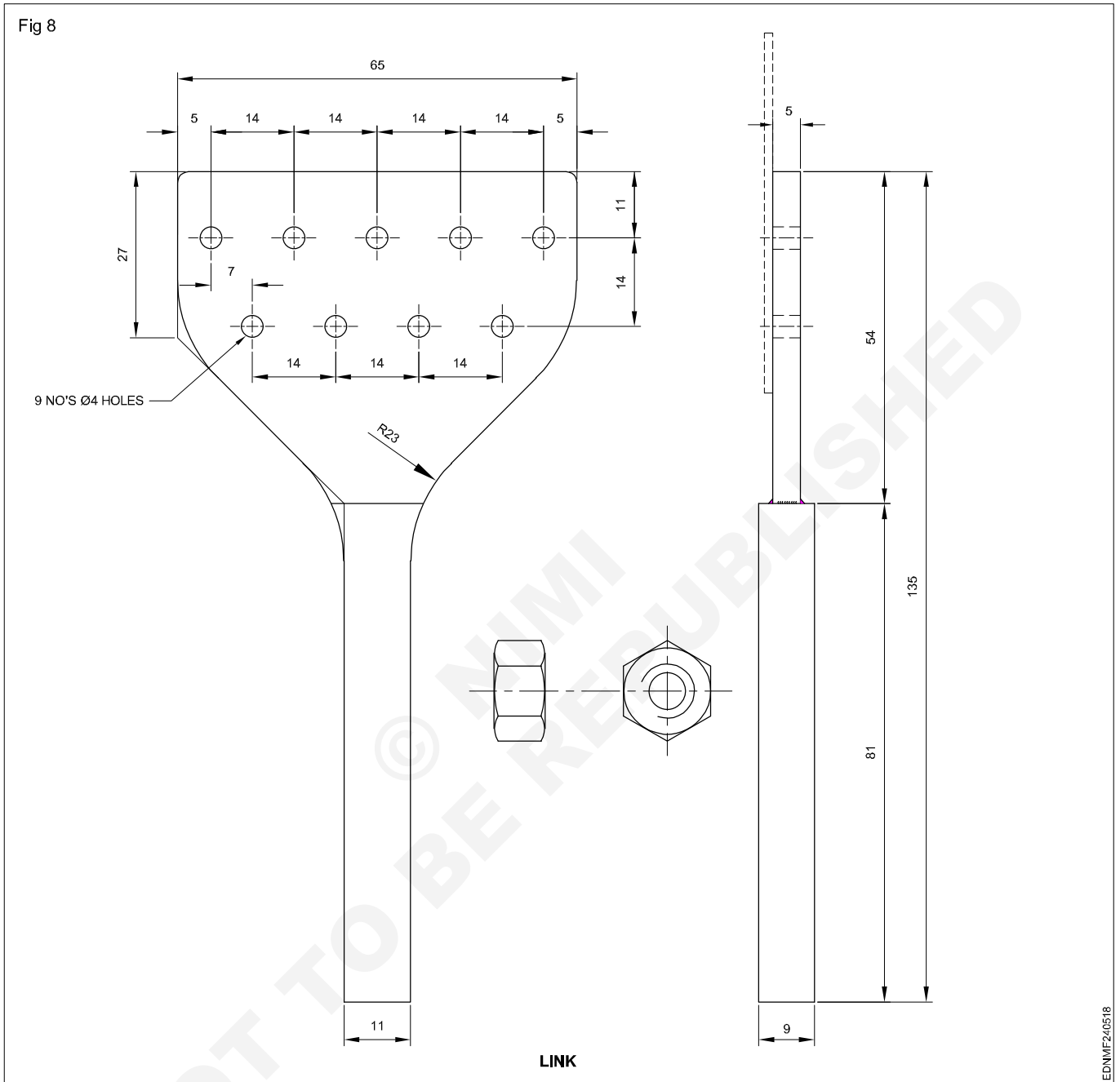

Brake assembly (Fig 9)

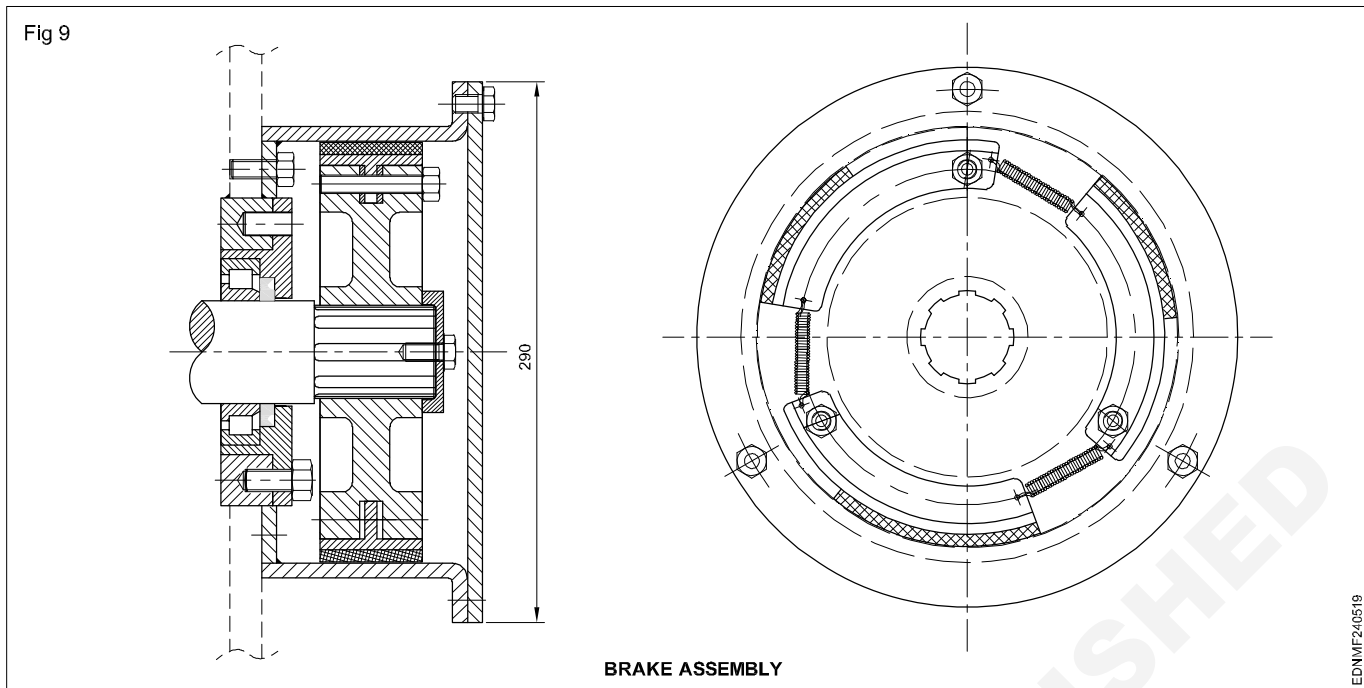

Read and write the following (Fig 9)

1 What is the name of the bearing?

2 What type of spring is used?

Winch Drum (Fig 10)

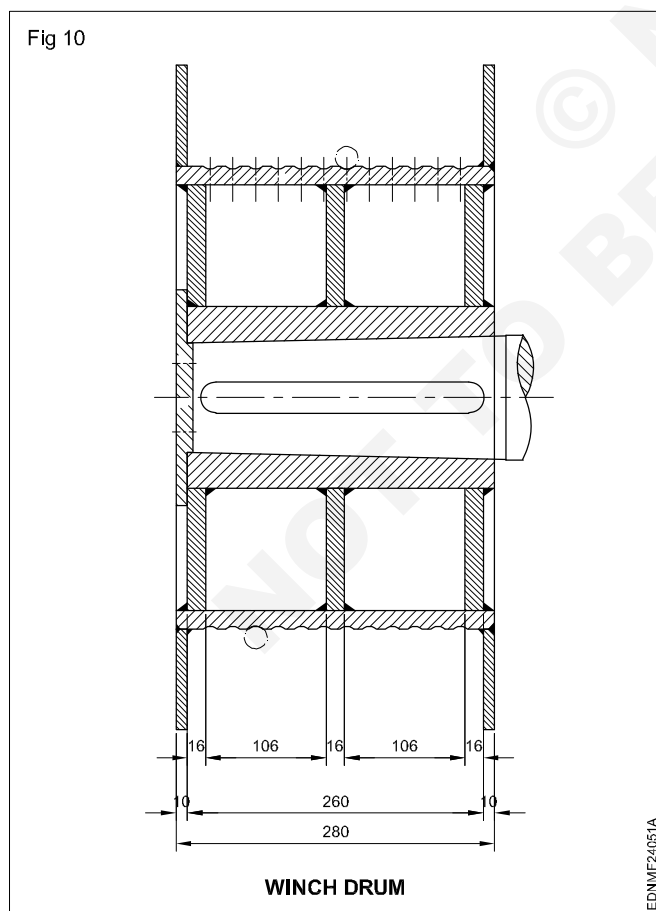

Read and write the following (Fig 10)

1 Where Winch drum is used?